

Papiersablonen können sich durch Luftfeuchtigkeit verändern. Verbindlich sind daher nur die Maßangaben.
 Paper templates might distort due to air moisture. Only the indicated measurements are therefore obligatory.
 Les gabarits en papier peuvent avoir des dimensions modifiées par l'humidité de l'air. Seules les cotes mentionnées doivent être respectées.



222

45

39+1

Bohrungen für Direktmontage
 Drilling for direct mounting
 Alésage pour montage direct

Bohrungen für Montageplatte
 Drillings for mounting plate
 Alésage pour platine de montage
 (Gr.: 3,4 / Size: 3,4 / Dim: 3,4)

Ø 2,5
 Ø 4,2 (M5)

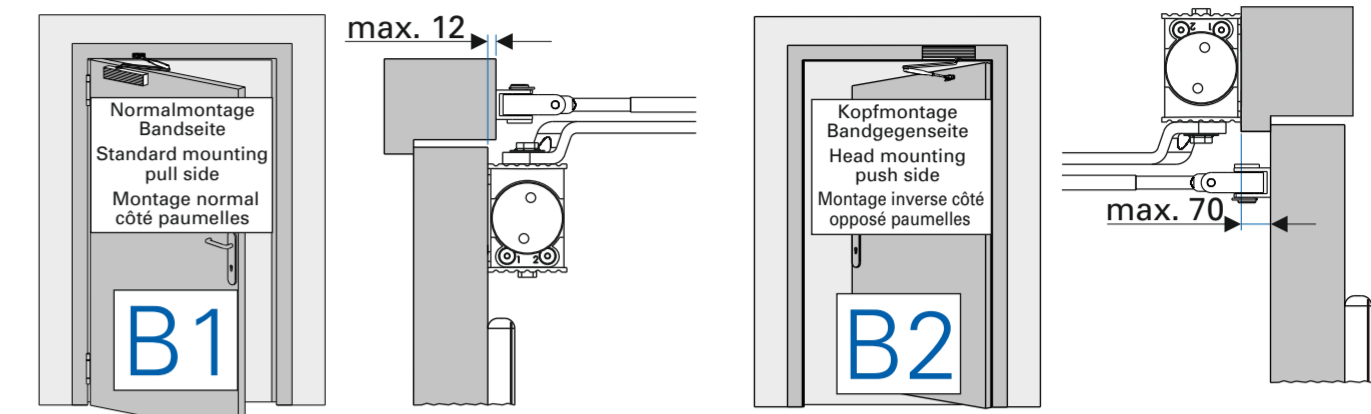
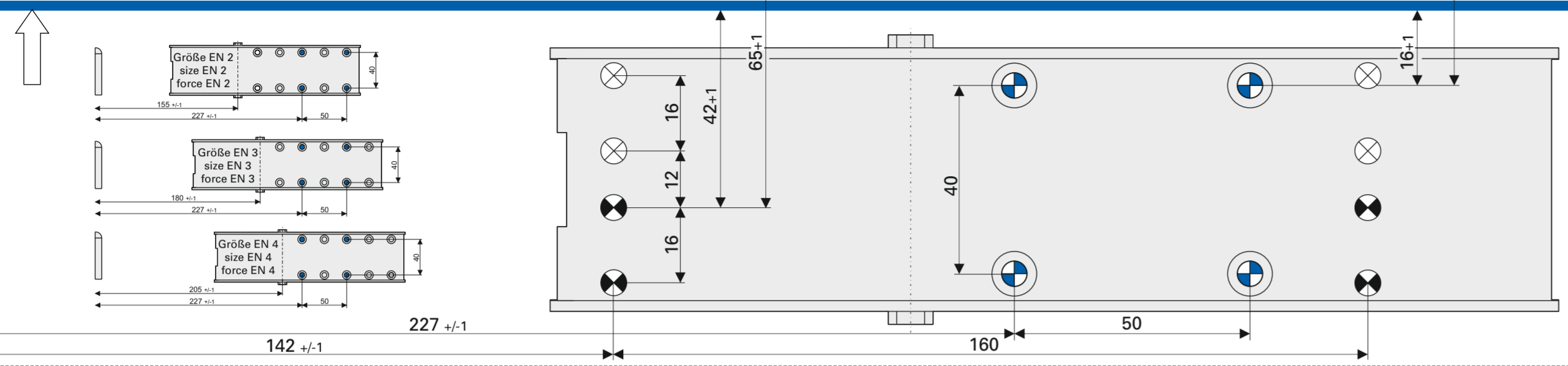

DIN links / left / gauche

TS-14 EN 2/3/4 ECO



CE	ECO Schulte GmbH & Co. KG Iserlohner Landstraße 89 D-58706 Menden	17
	0432-CPR-00099-10	EN 1154:1996+A1:2002 / AC:2006

TS-14 EN 2/3/4	Türschließergröße Door closer size Force de ferme porte	Für max. Türbreite For max. door with Pour largeur de porte max.
	■2	850 mm
	■3	950 mm
■4	1100 mm	

Abkürzungen	Abbreviations	Abréviations
SG Schließgeschwindigkeit	CS Closing speed	VF Vitesse de fermeture
ES Endschlag	LS Latching speed	CF Coup final

Für die Montage dürfen ausschließlich Originalteile des Herstellers verwendet werden. Die Montagearbeiten müssen gemäß Anleitung von einer qualifizierten Person durchgeführt werden. Bei Nichtbeachtung entfällt jeglicher Garantieanspruch.
 Only original parts have to be used. The assembly has to be made by a qualified person according to the mounting instruction. In case of non-respect the guarantee is invalid.
 Impérativement utiliser la notice de montage fournie par le fabricant. La mise en œuvre et le montage doivent être exécutés par du personnel qualifié. Le non respect de ces règles annule catégoriquement tout droit de garantie

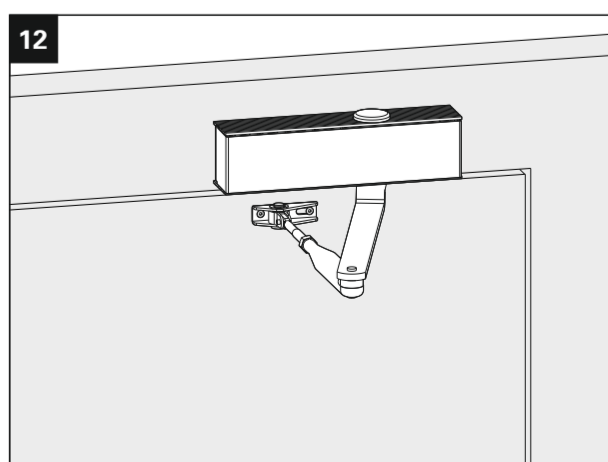
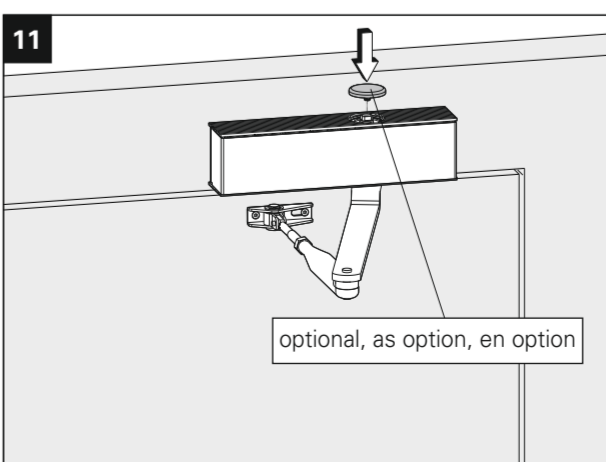
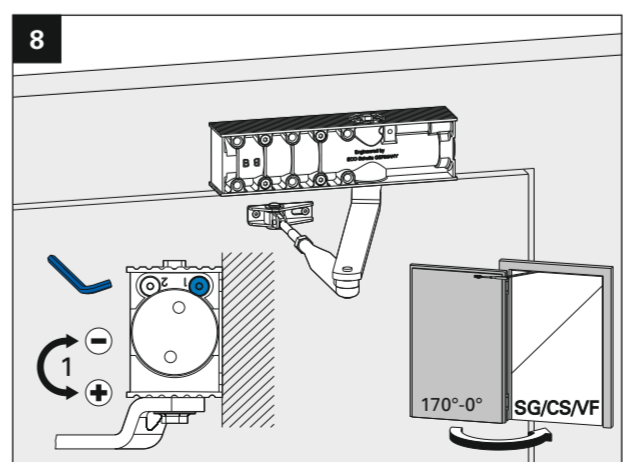
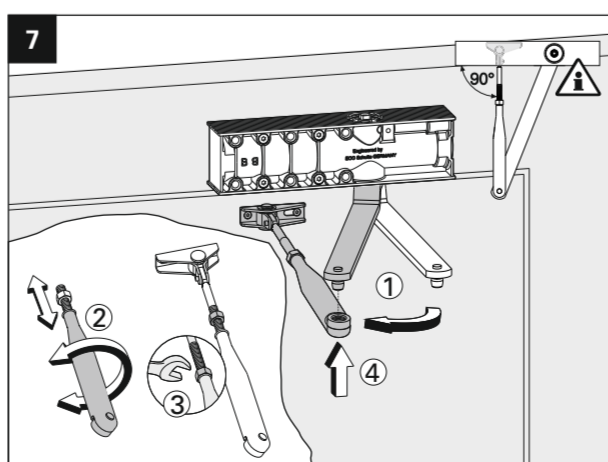
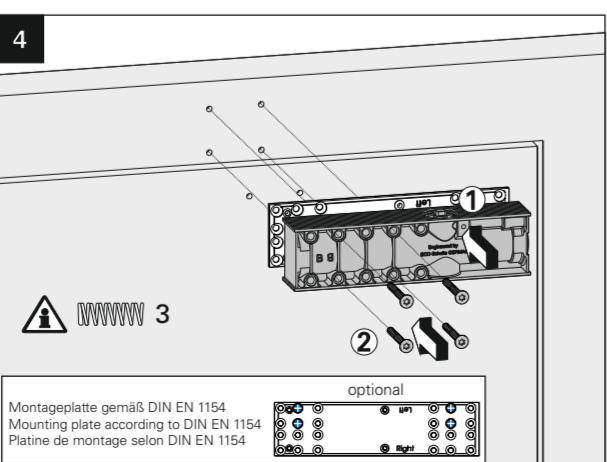
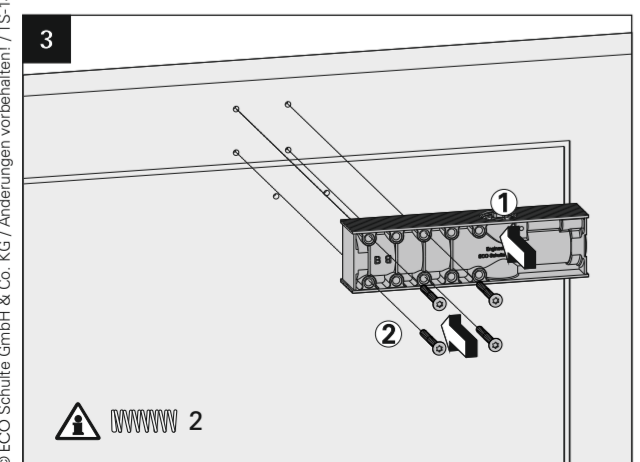
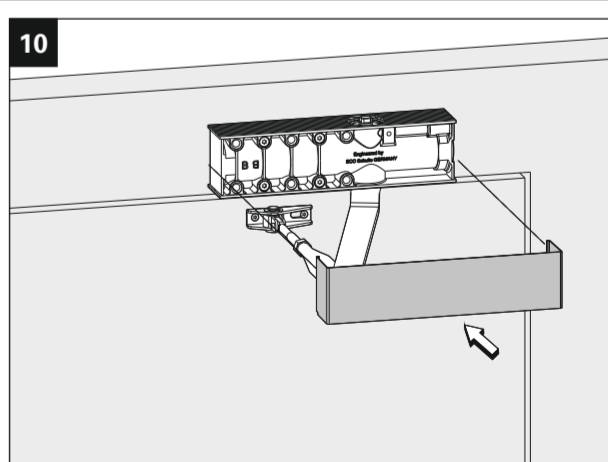
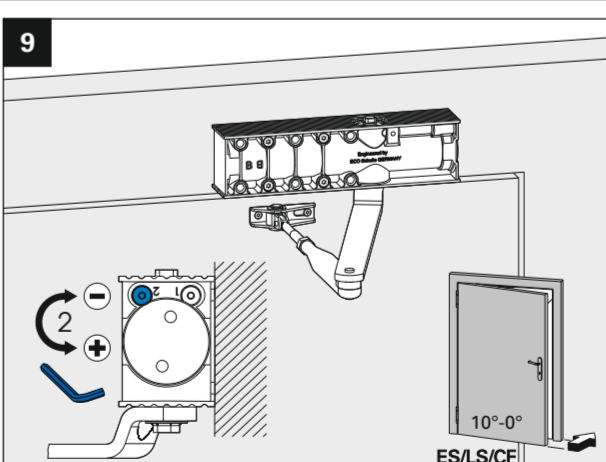
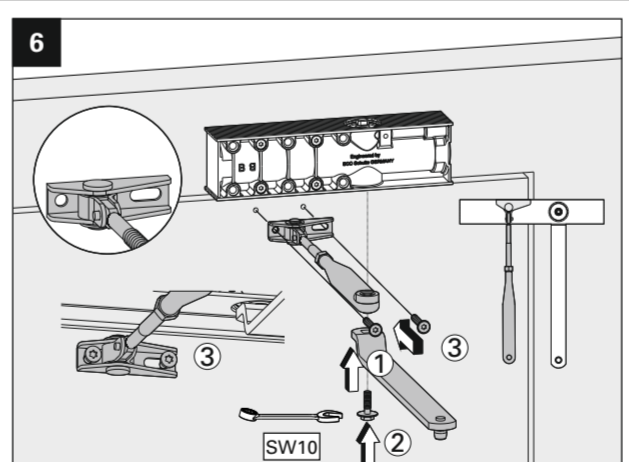
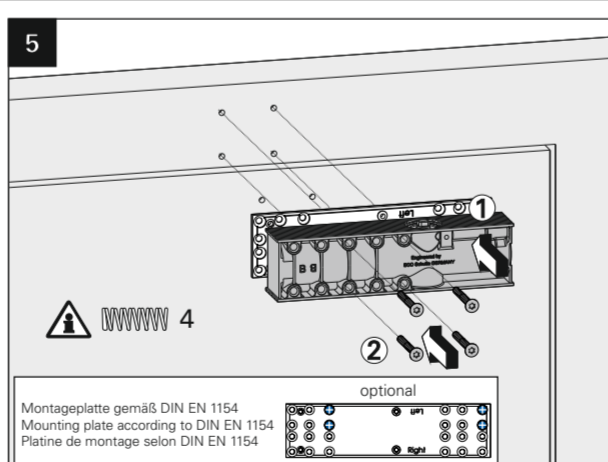
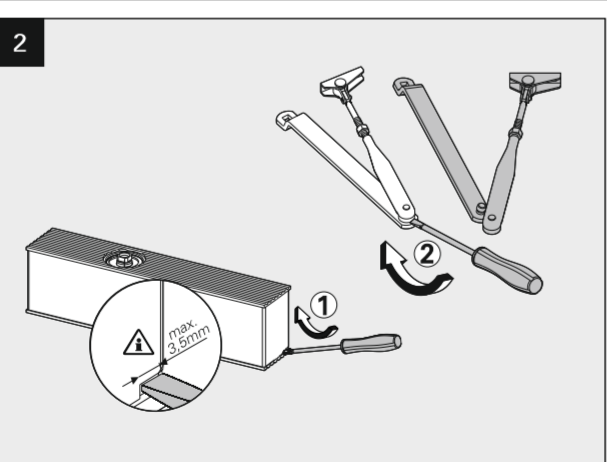
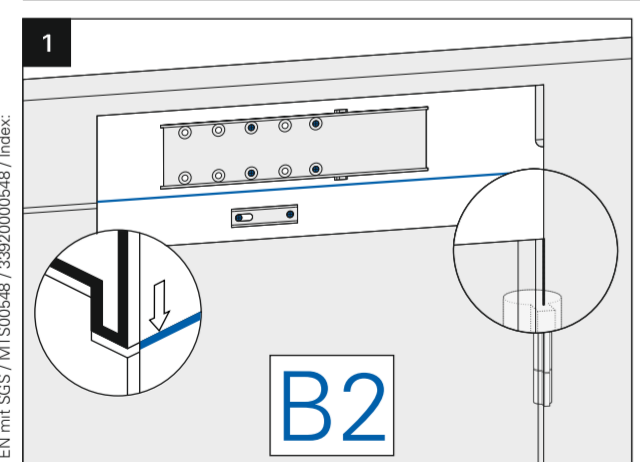
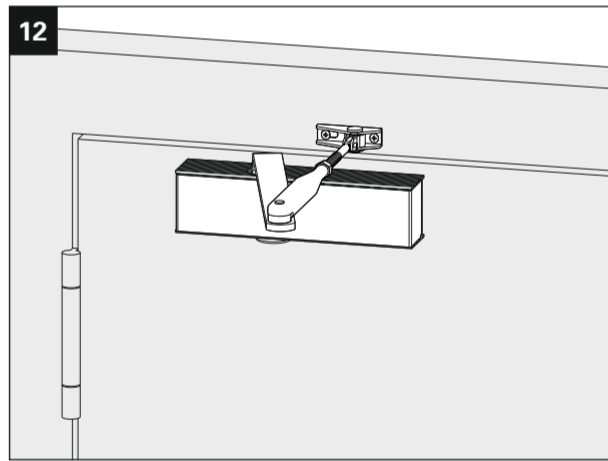
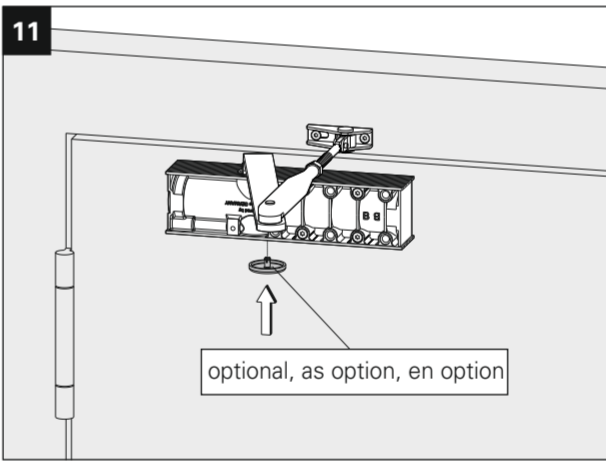
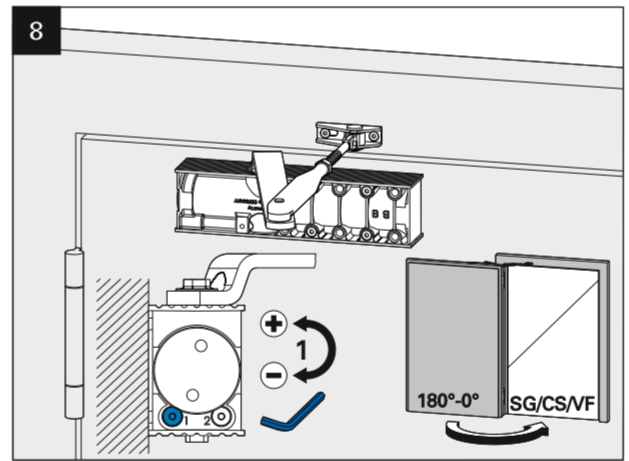
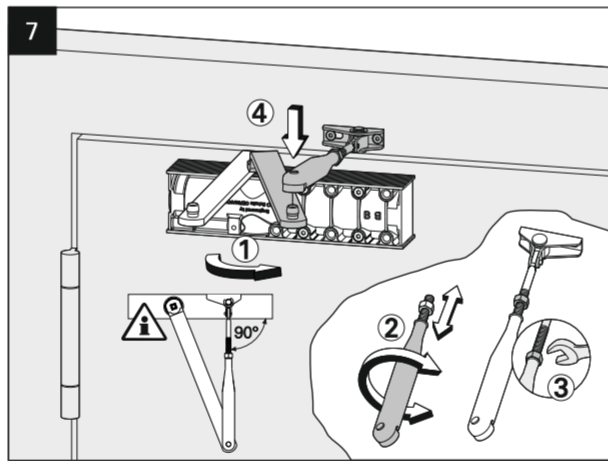
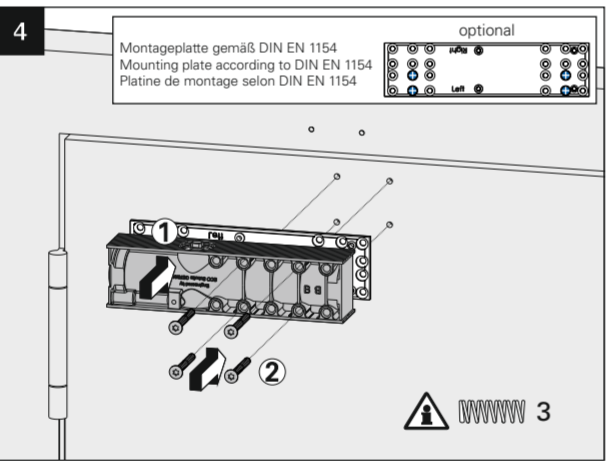
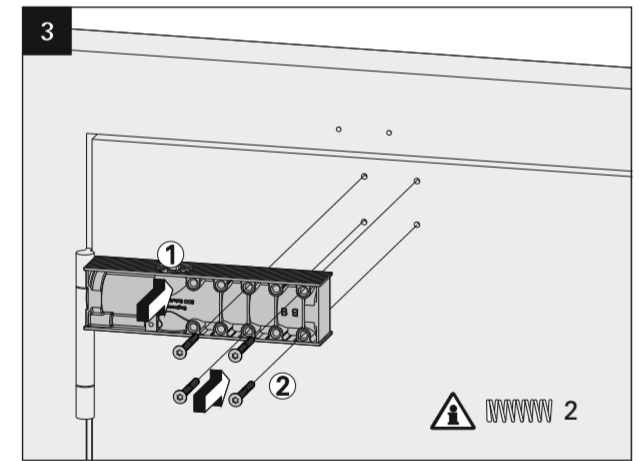
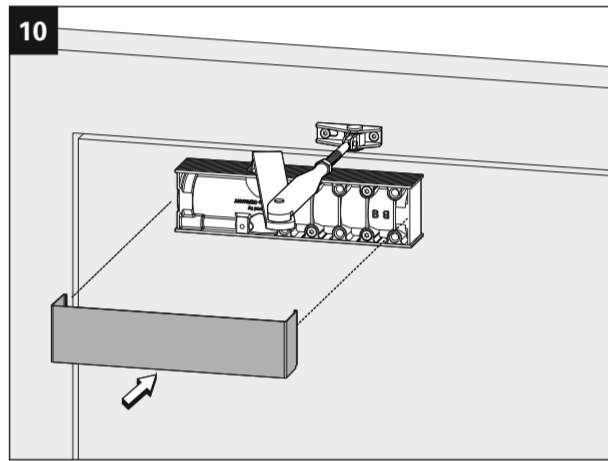
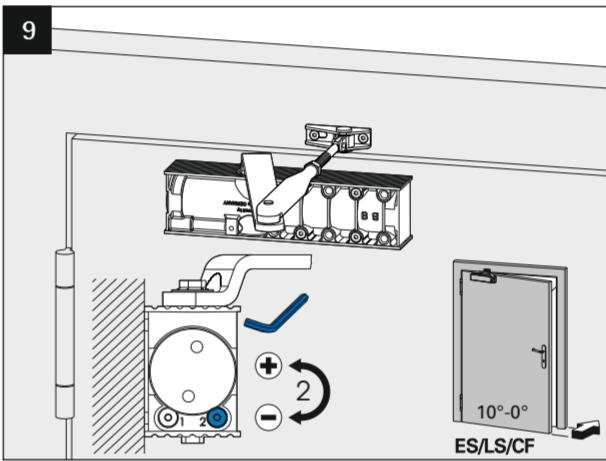
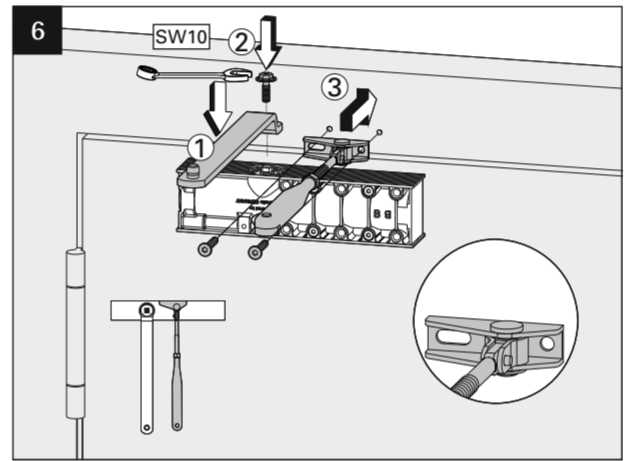
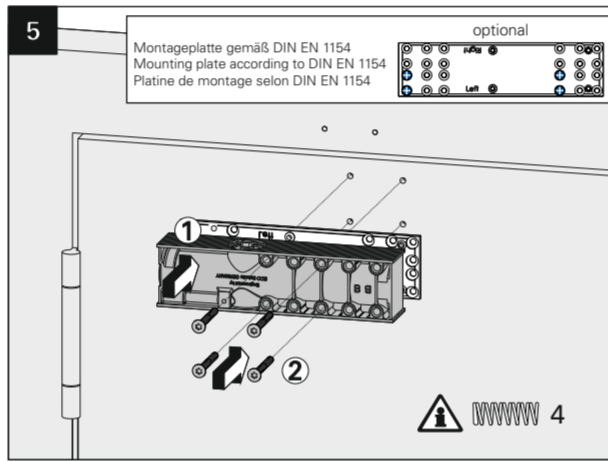
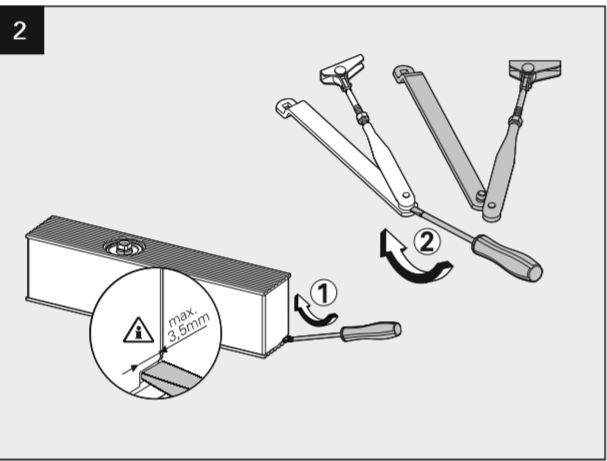
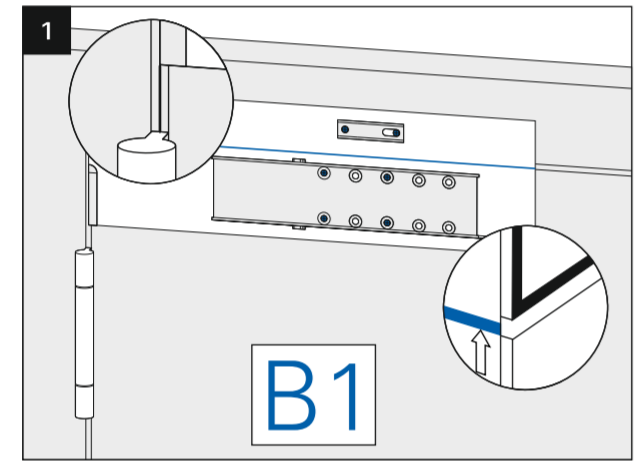

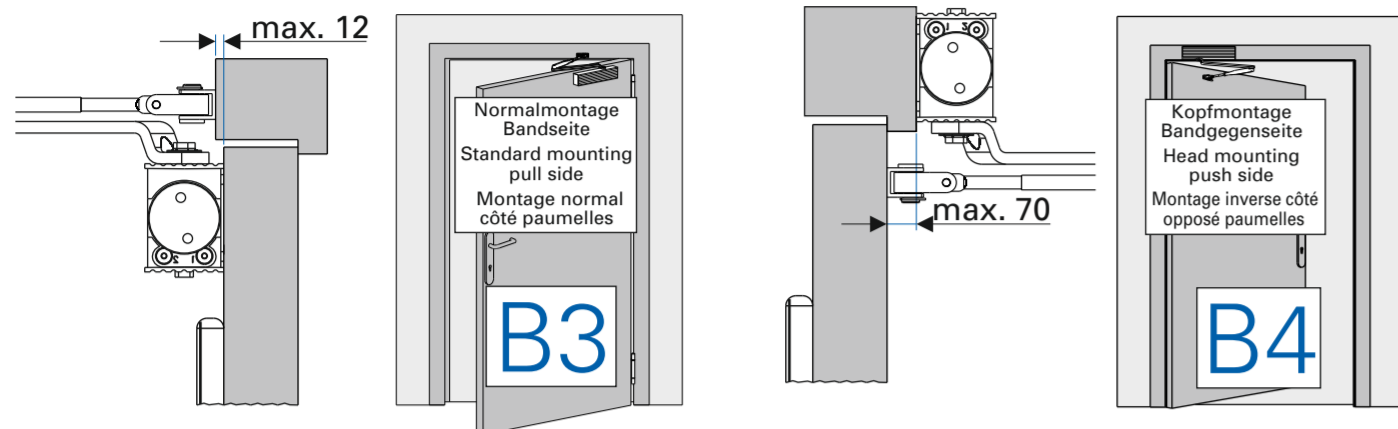

DIN rechts / right / droite

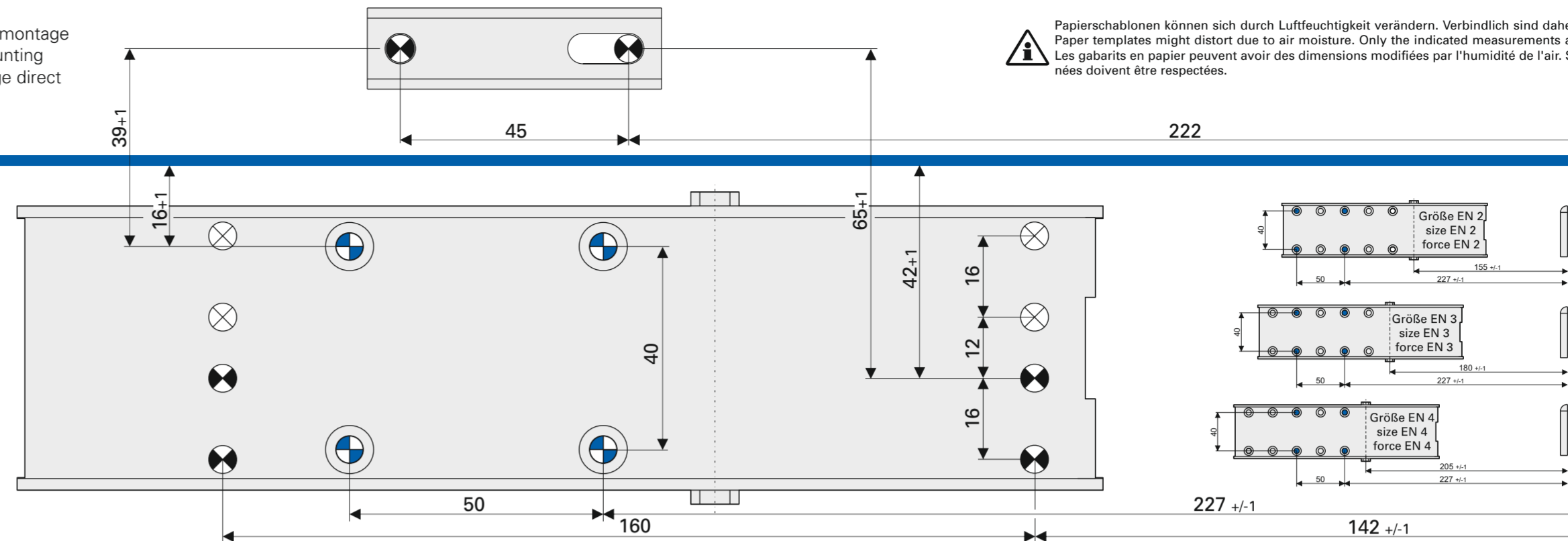

TS-14 EN 2/3/4 ECO



	ECO Schulte GmbH & Co. KG Iserlohner Landstraße 89 D-58706 Menden	17
0432-CPR-00099-10	EN 1154:1996+A1:2002 / AC:2006	4 8 2/3/4 1 1 3

TS-14 EN 2/3/4	Türschließergröße Door closer size Force de ferme porte	Für max. Türbreite For max. door with Pour largeur de porte max.
	■2	850 mm
	■3	950 mm
■4	1100 mm	

Abkürzungen	Abbreviations	Abréviations
SG Schließgeschwindigkeit	CS Closing speed	VF Vitesse de fermeture
ES Endschlag	LS Latching speed	CF Coup final

Für die Montage dürfen ausschließlich Originalteile des Herstellers verwendet werden. Die Montagearbeiten müssen gemäß Anleitung von einer qualifizierten Person durchgeführt werden. Bei Nichtbeachtung entfällt jeglicher Garantieanspruch.

Only original parts have to be used. The assembly has to be made by a qualified person according to the mounting instruction. In case of non-respect the guarantee is invalid.

Impérativement utiliser la notice de montage fournie par le fabricant. La mise en œuvre et le montage doivent être exécutés par du personnel qualifié. Le non respect de ces règles annule catégoriquement tout droit de garantie.

