

- Bohrungen für Montageplatte
Drillings for mounting plate
Alésage pour platine de montage
- Bohrungen für Direktmontage
Drillings for direct mounting
Alésage pour montage direct

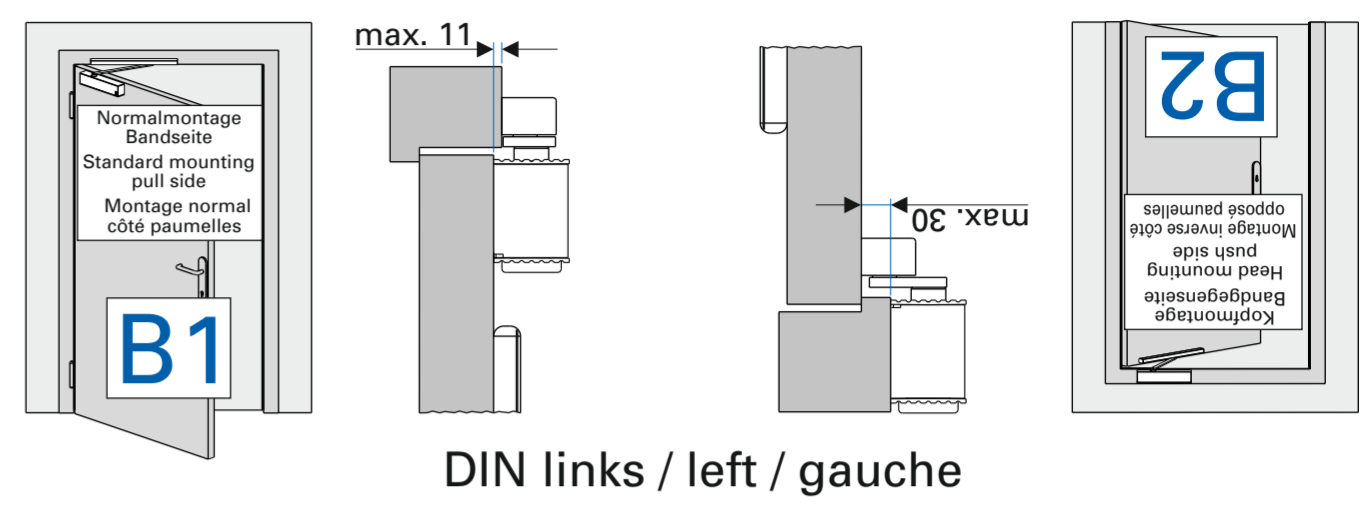

TS-31 K EN 1-3
TS-41 K EN 1-4

CE	ECO Schulte GmbH & Co. KG Iserlohner Landstraße 89 D-58706 Menden	17
	0432-CPR-00099-09	EN 1154:1996+A1:2002 / AC:2006

TS-31 EN 1-3	Türschließergröße Door closer size Force de ferme porte	Max. Türbreite Max. door width Largeur de porte max.	Umdrehungen Rotations Rotations
■ 1	750 mm	-11	
■ 2	850 mm	-6	
■ 3	950 mm	0	

TS-41 EN 1-4	Türschließergröße Door closer size Force de ferme porte	Max. Türbreite Max. door width Largeur de porte max.	Umdrehungen Rotations Rotations
■ 1	750 mm	-7	
■ 2	850 mm	-4	
■ 3	950 mm	0	
■ 4	1100 mm	+5	

Für die Montage dürfen ausschließlich Originalteile des Herstellers verwendet werden. Die Montagearbeiten müssen gemäß Anleitung von einer qualifizierten Person durchgeführt werden. Bei Nichtbeachtung entfällt jeglicher Garantieanspruch. Diese Anleitung ist vom Monteur nach der Montage an den Betreiber weiterzugeben.
Only original parts have to be used. The assembly has to be made by a qualified person according to the mounting instruction. In case of non-respect the guarantee is invalid. This instruction is to be handed over to the operator by the fitter after assembly!
Impérativement utiliser la notice de montage fournie par le fabricant. La mise en œuvre et le montage doivent être exécutés par du personnel qualifié. Le non respect de ces règles annule catégoriquement tout droit de garantie. Cette instruction est à remettre par le poseur à l'exploitant après montage.

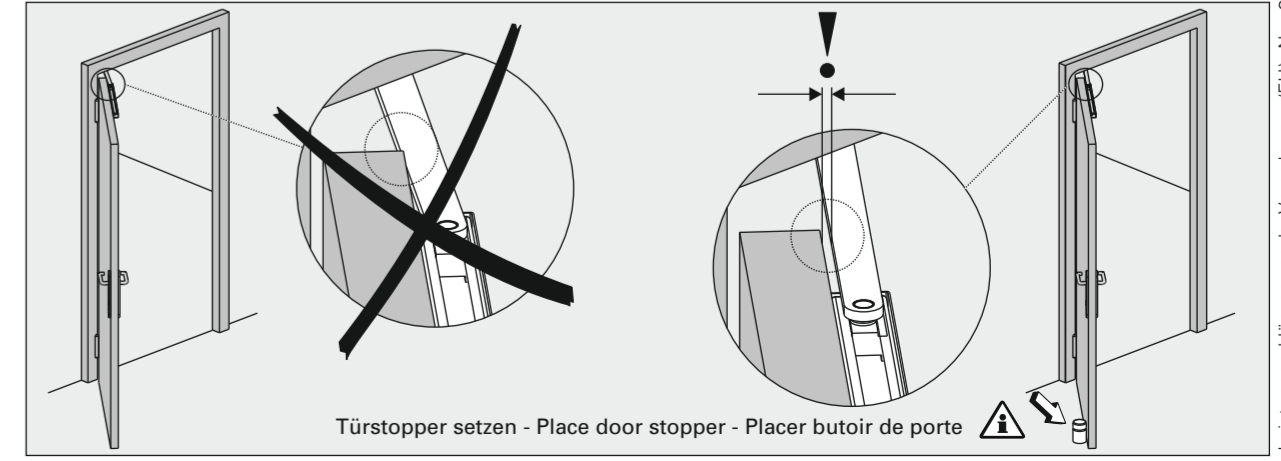
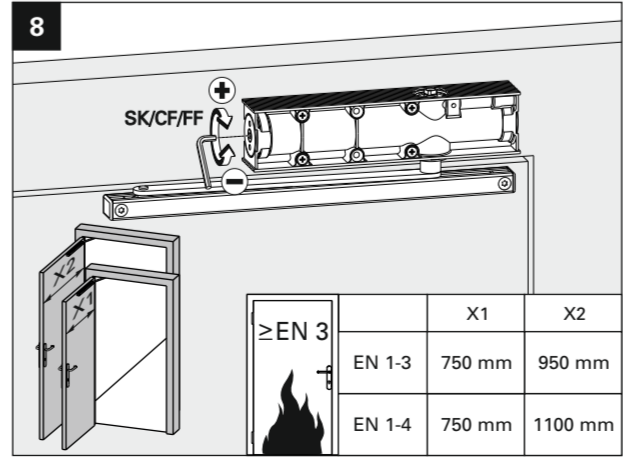
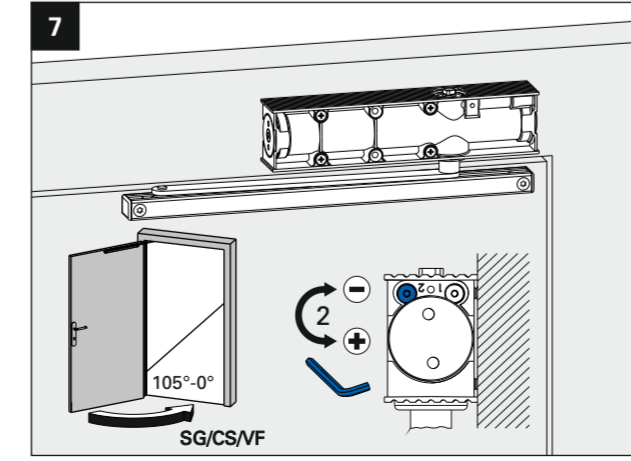
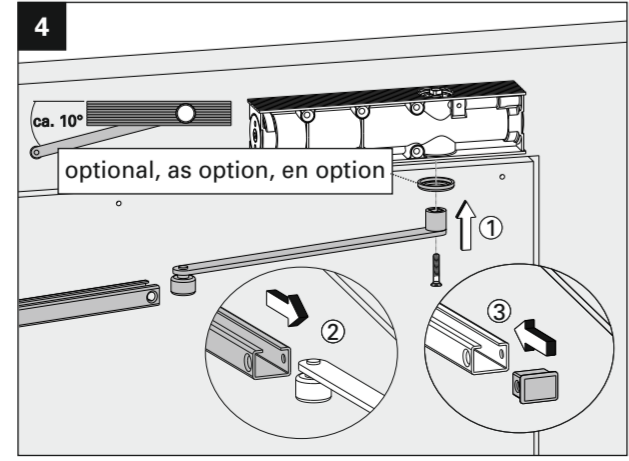
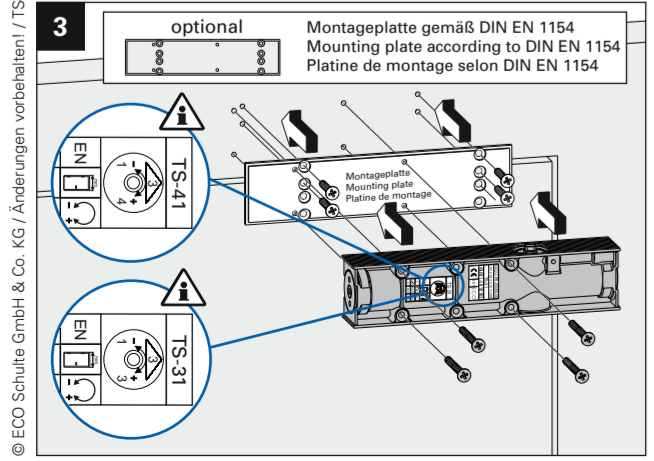
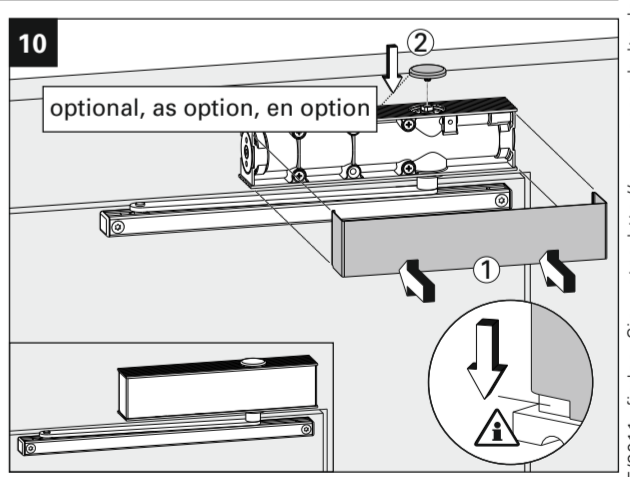
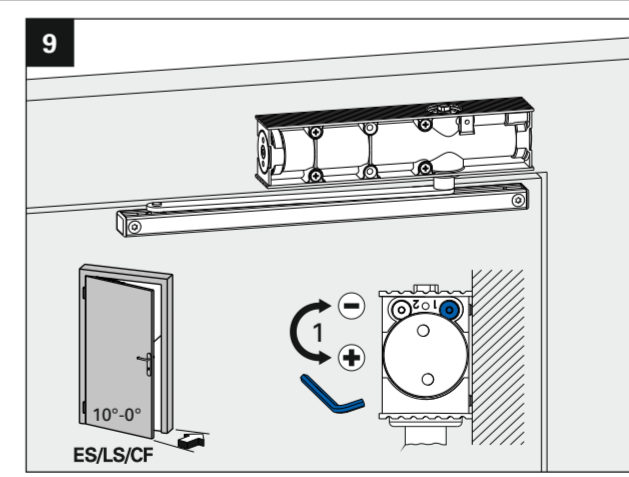
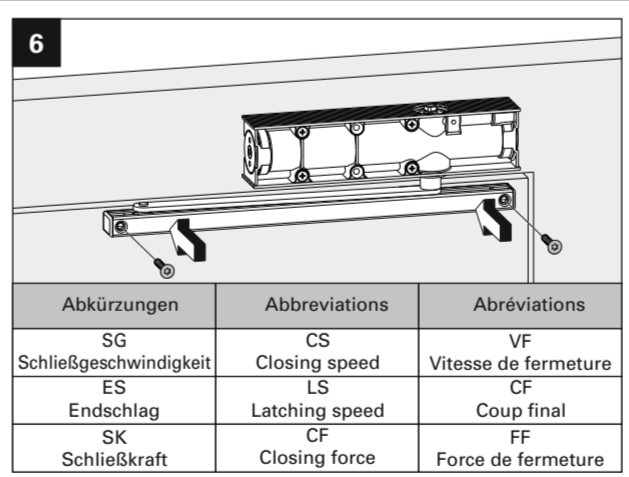
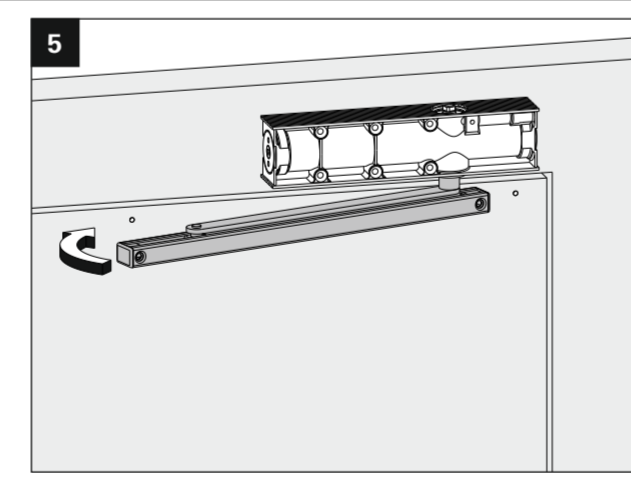
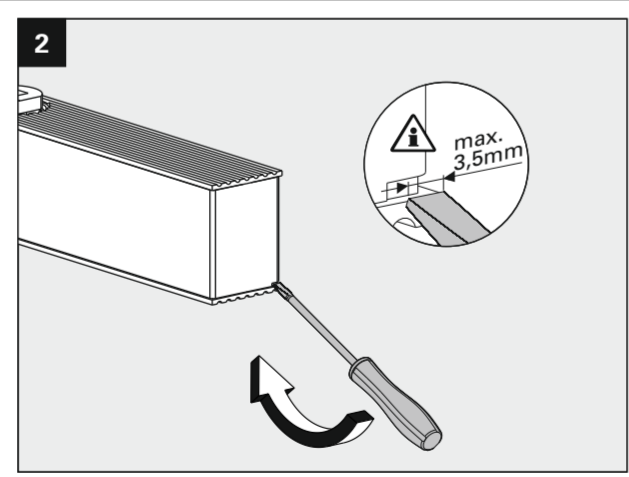
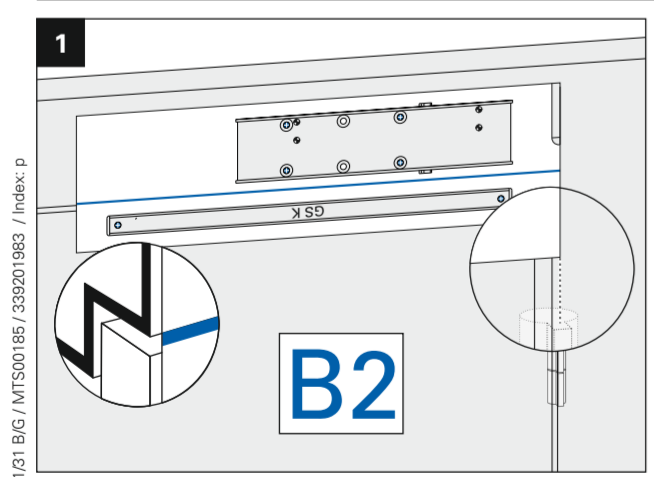
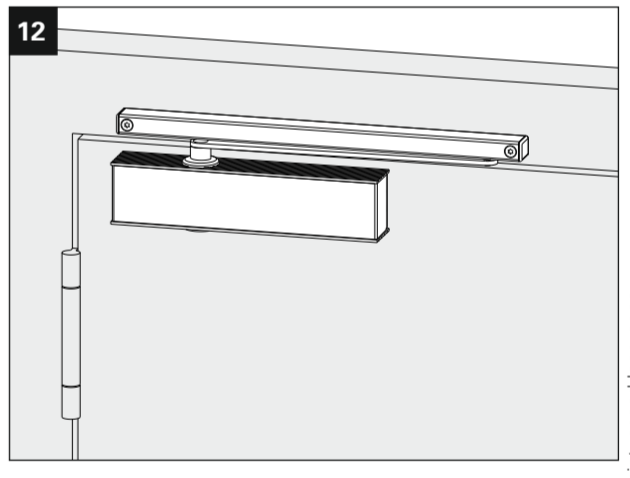
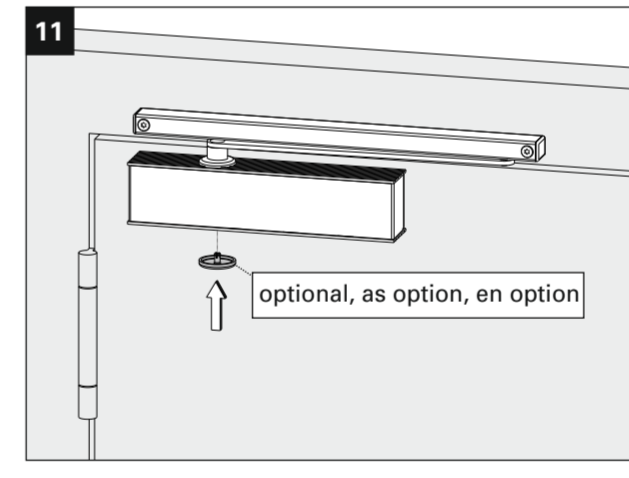
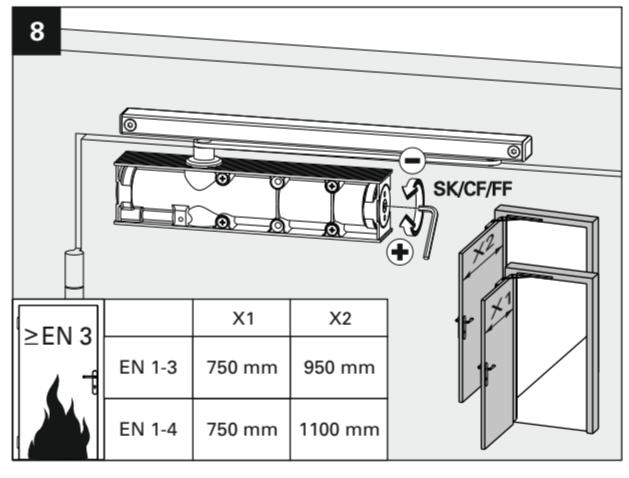
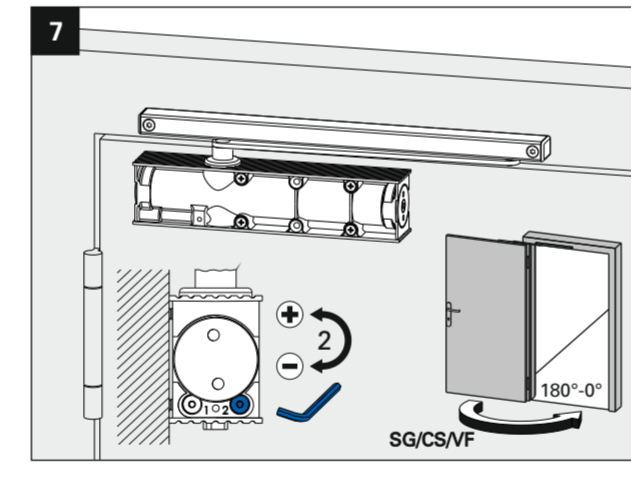
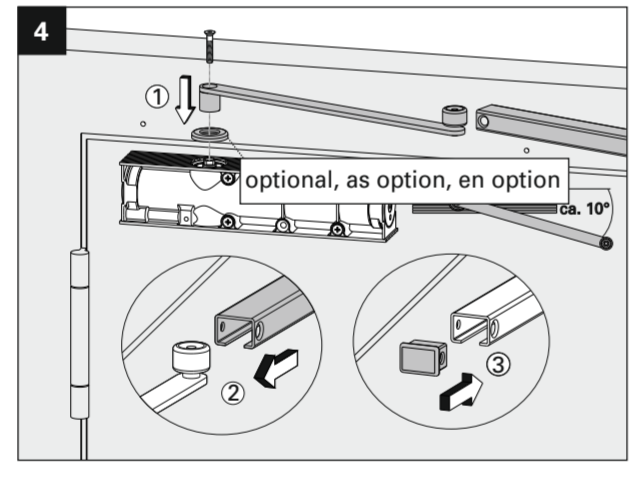
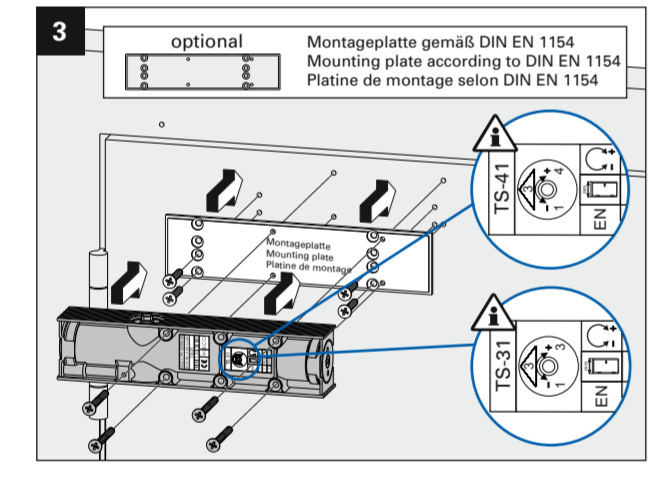
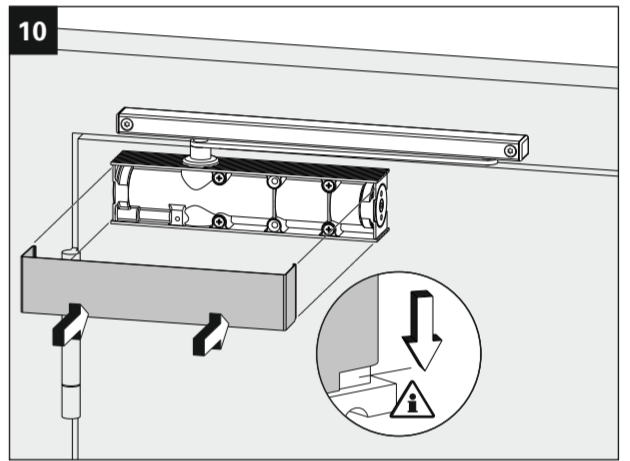
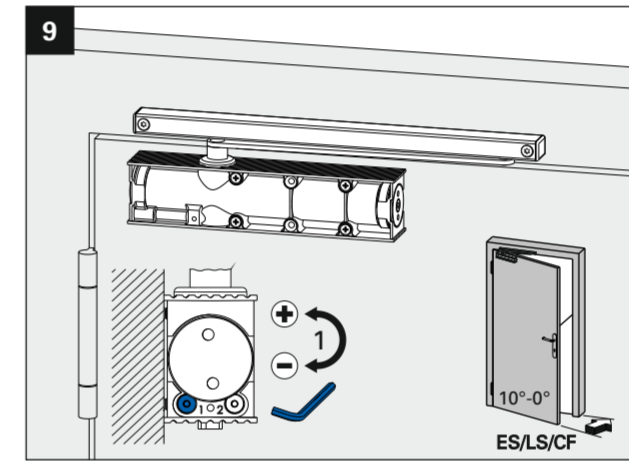
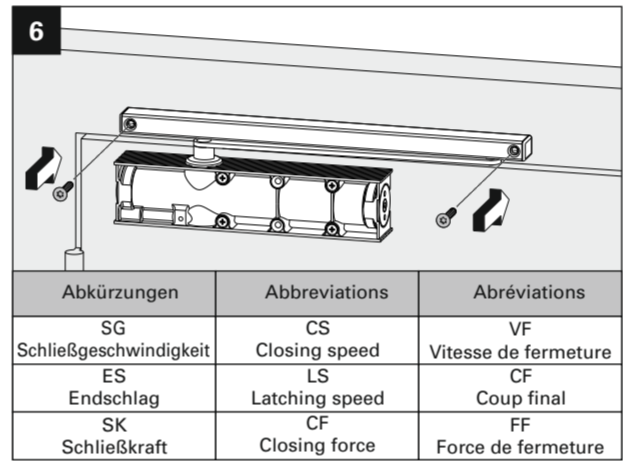
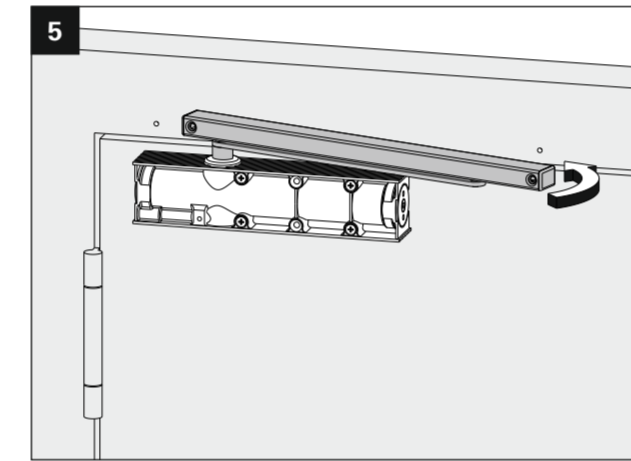
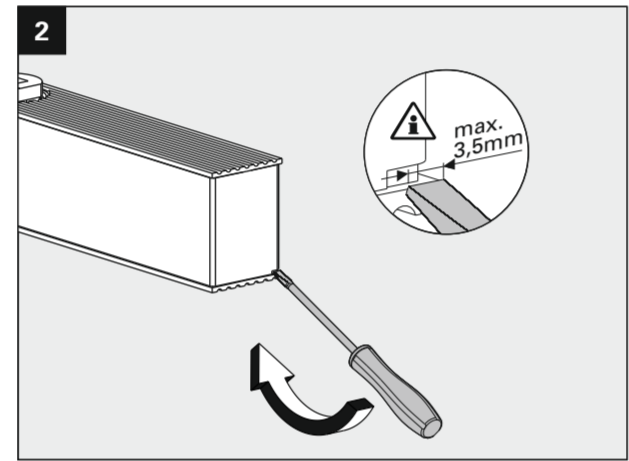
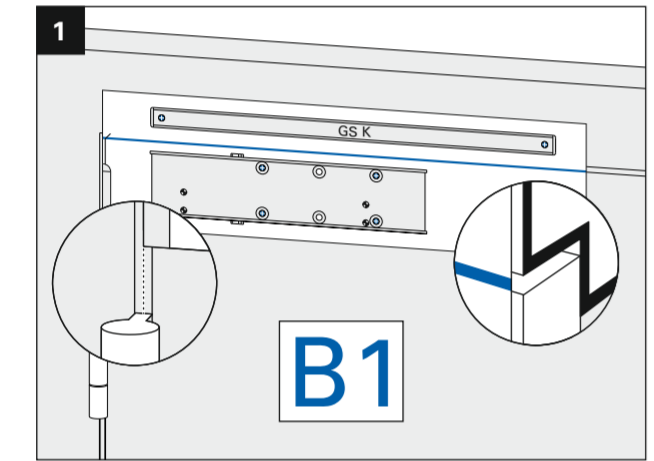

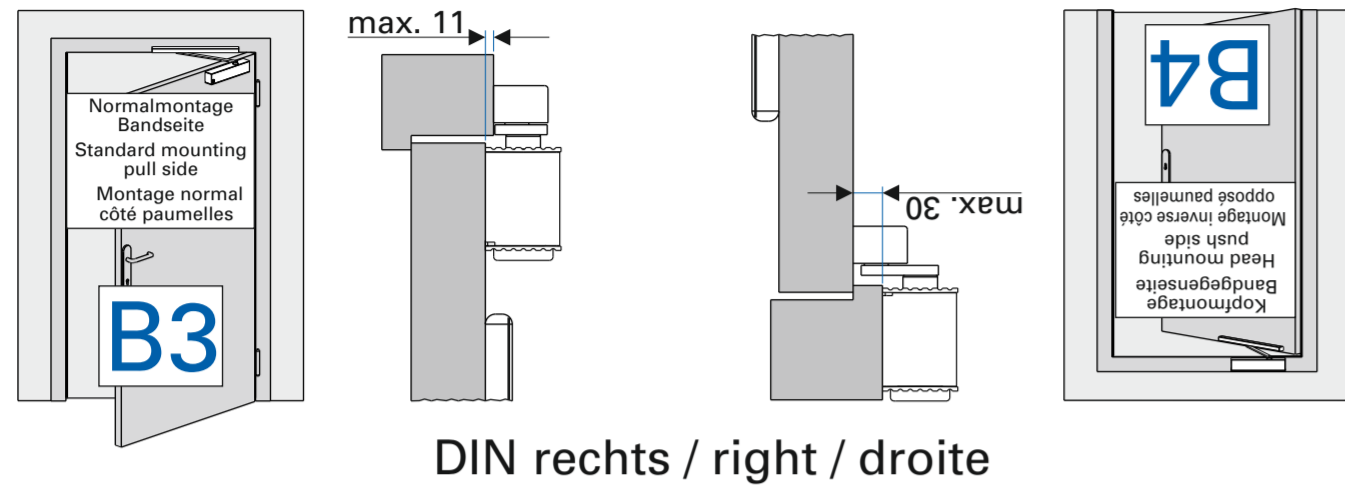
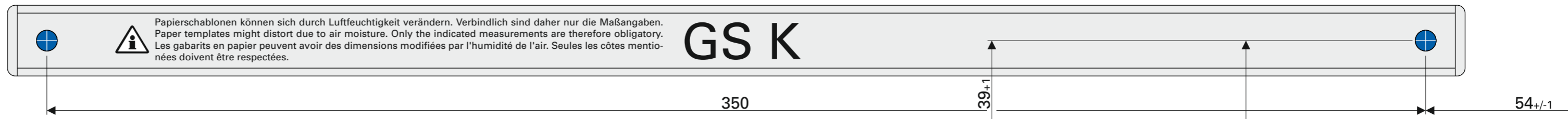

- Bohrungen für Montageplatte
Drillings for mounting plate
Alésage pour platine de montage
- Bohrungen für Direktmontage
Drillings for direct mounting
Alésage pour montage direct

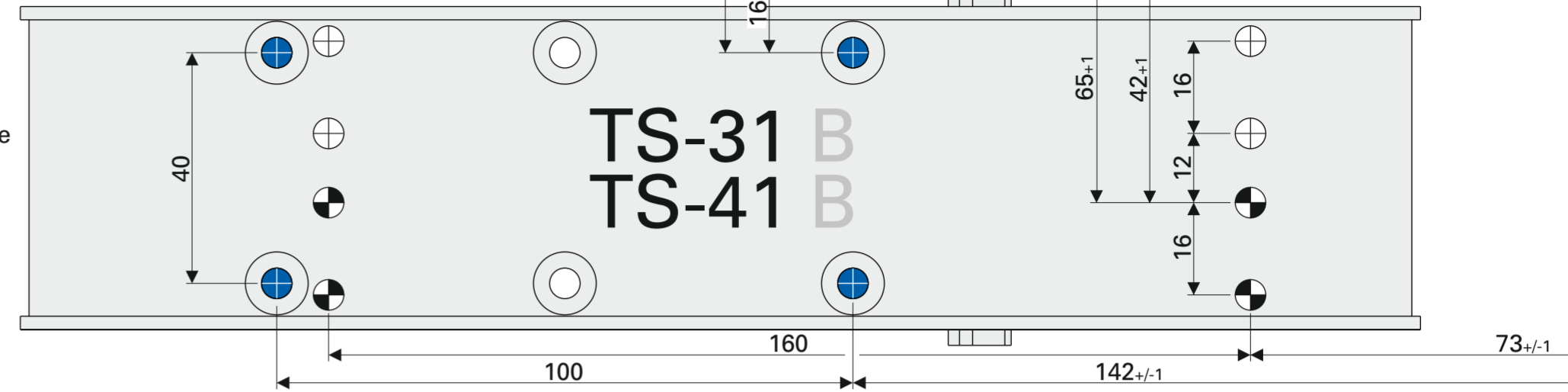

DIN rechts / right / droite

TS-31 K EN 1-3
TS-41 K EN 1-4



CE	ECO Schulte GmbH & Co. KG Iserlohner Landstraße 89 D-58706 Menden	17
	0432-CPR-00099-09	EN 1154:1996+A1:2002 / AC:2006

TS-31 EN 1-3	Türschließergröße Door closer size Force de ferme porte	Max. Türbreite Max. door width Largeur de porte max.	Umdrehungen Rotations Rotations
■ 1	750 mm	-11	
■ 2	850 mm	-6	
■ 3	950 mm	0	

TS-41 EN 1-4	Türschließergröße Door closer size Force de ferme porte	Max. Türbreite Max. door width Largeur de porte max.	Umdrehungen Rotations Rotations
■ 1	750 mm	-7	
■ 2	850 mm	-4	
■ 3	950 mm	0	
■ 4	1100 mm	+5	

Für die Montage dürfen ausschließlich Originalteile des Herstellers verwendet werden. Die Montagearbeiten müssen gemäß Anleitung von einer qualifizierten Person durchgeführt werden. Bei Nichtbeachtung entfällt jeglicher Garantieanspruch. Diese Anleitung ist vom Monteur nach der Montage an den Betreiber weiterzugeben!
 Only original parts have to be used. The assembly has to be made by a qualified person according to the mounting instruction. In case of non-respect the guarantee is invalid. This instruction is to be handed over to the operator by the fitter after assembly!
 Impérativement utiliser la notice de montage fournie par le fabricant. La mise en œuvre et le montage doivent être exécutés par du personnel qualifié. Le non respect de ces règles annule catégoriquement tout droit de garantie. Cette instruction est à remettre par le poseur à l'exploitant après montage.

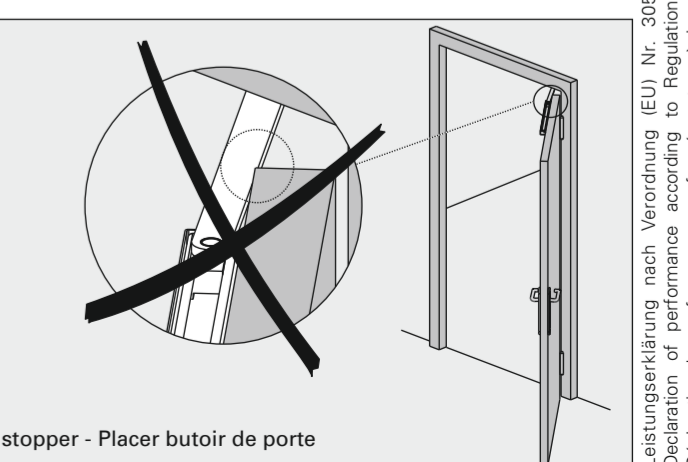
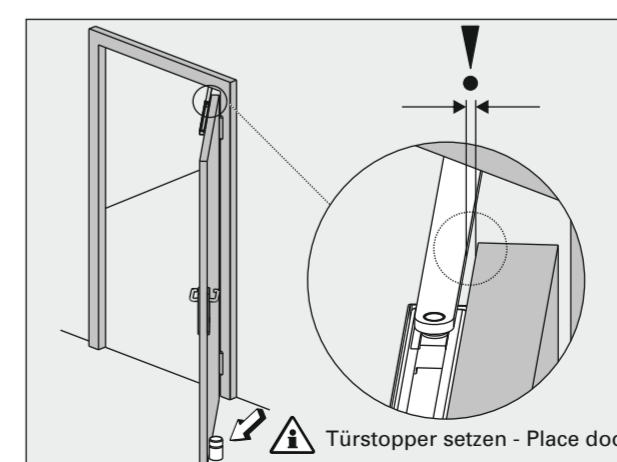
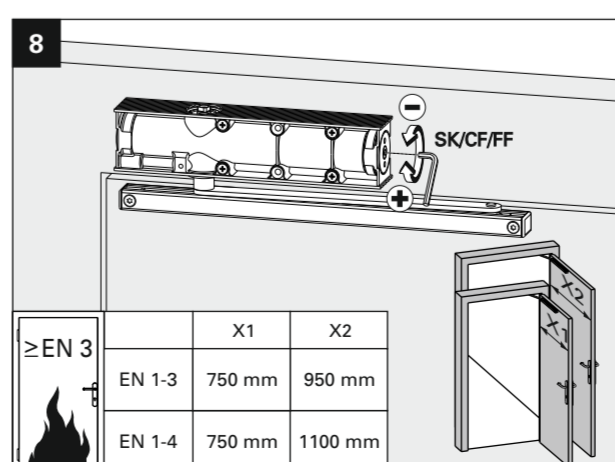
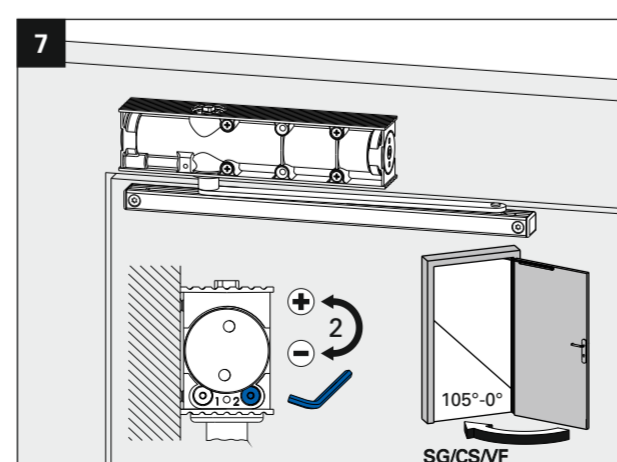
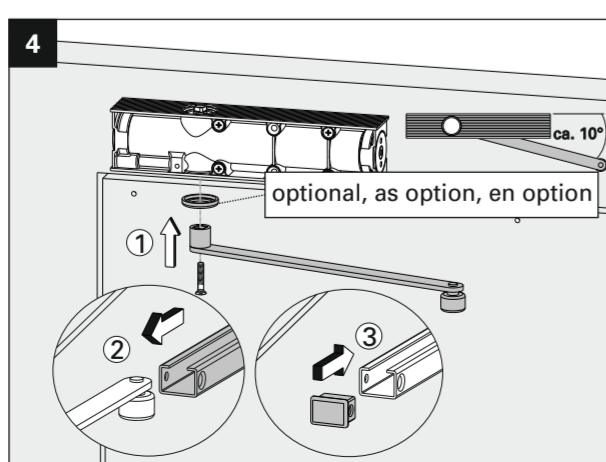
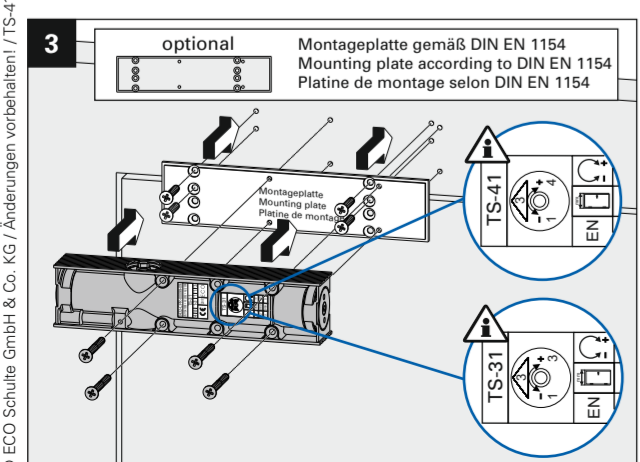
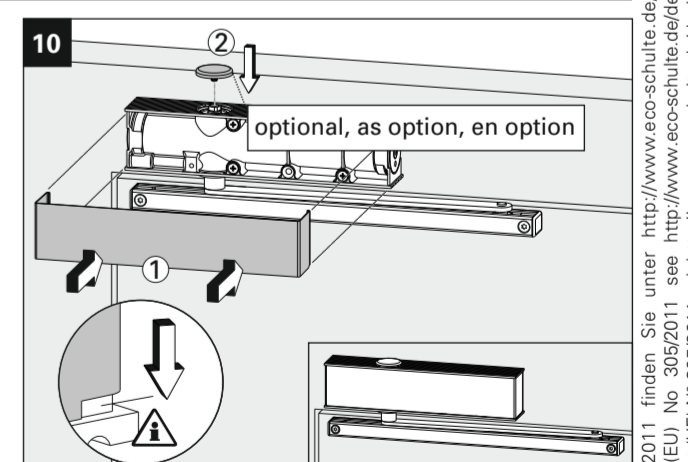
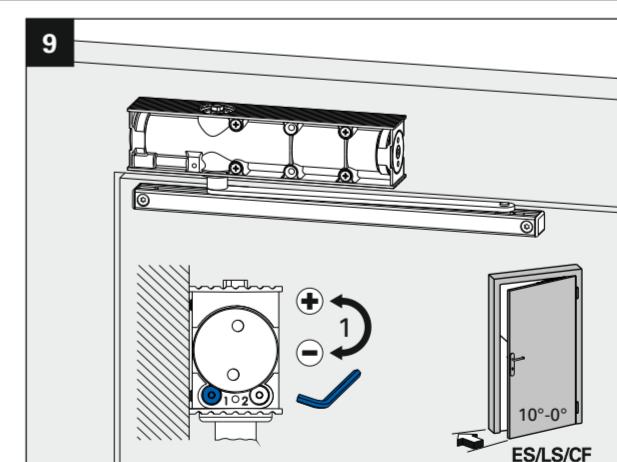
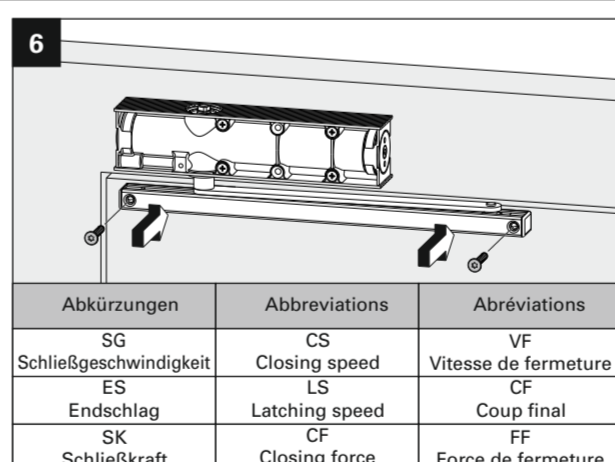
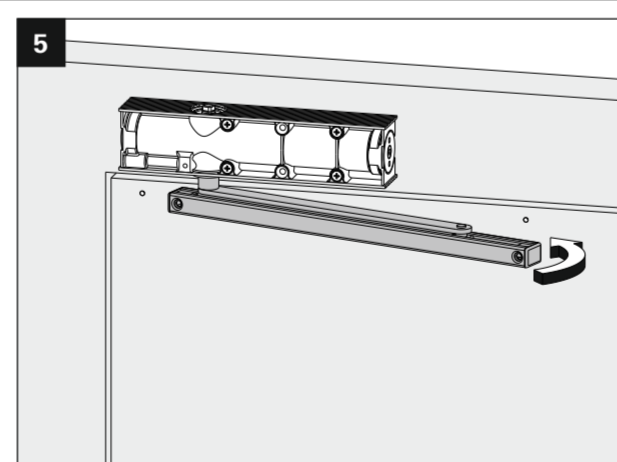
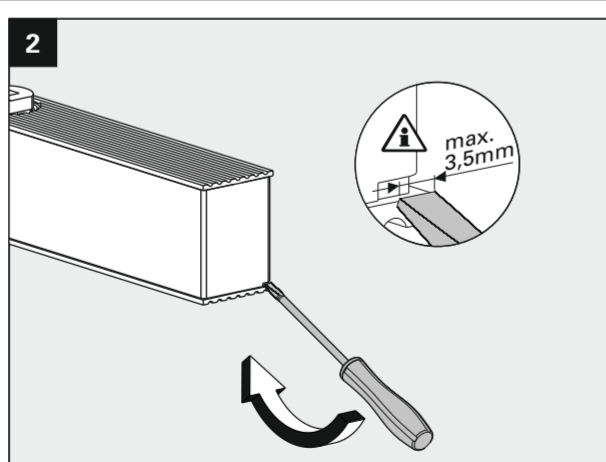
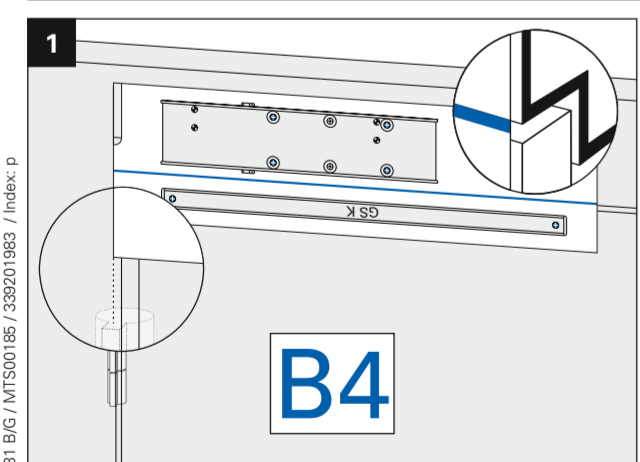
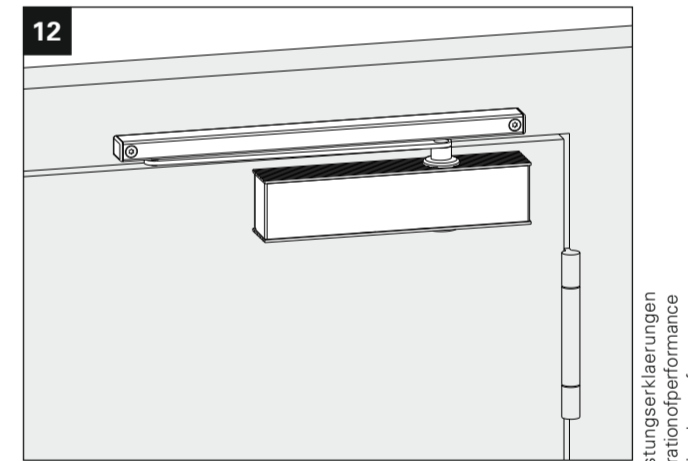
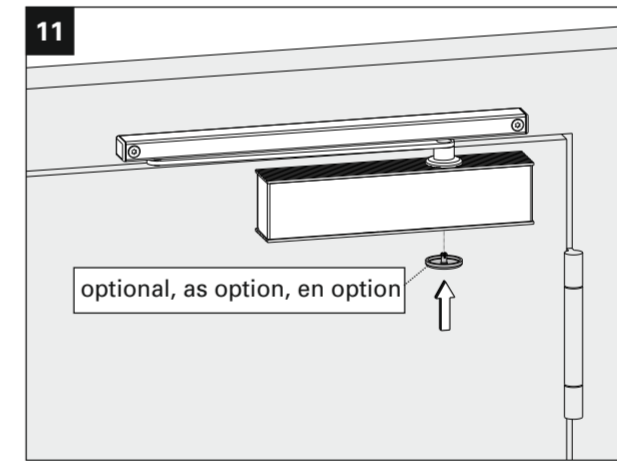
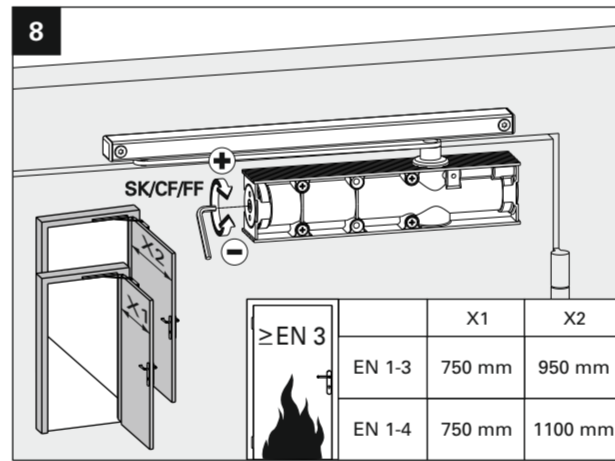
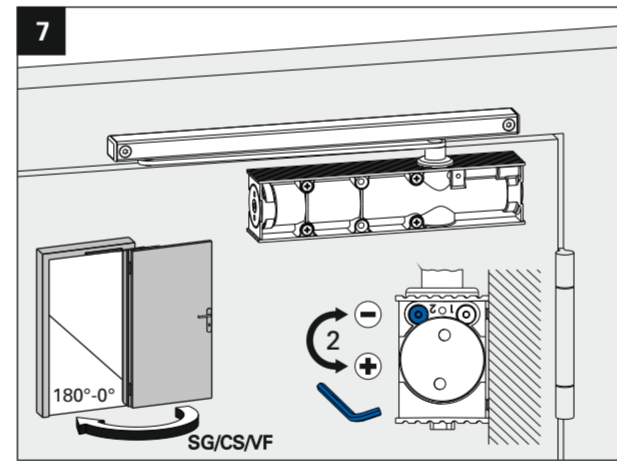
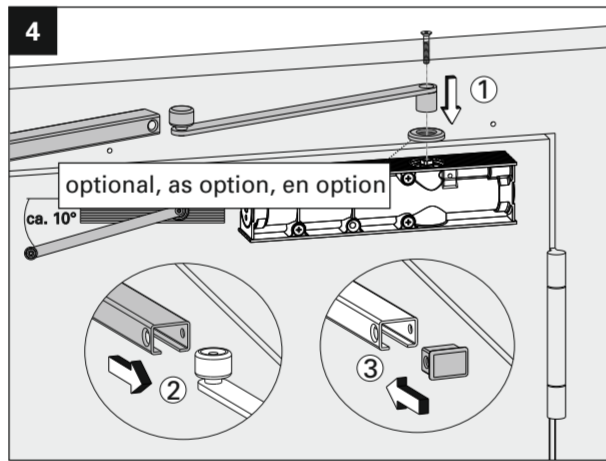
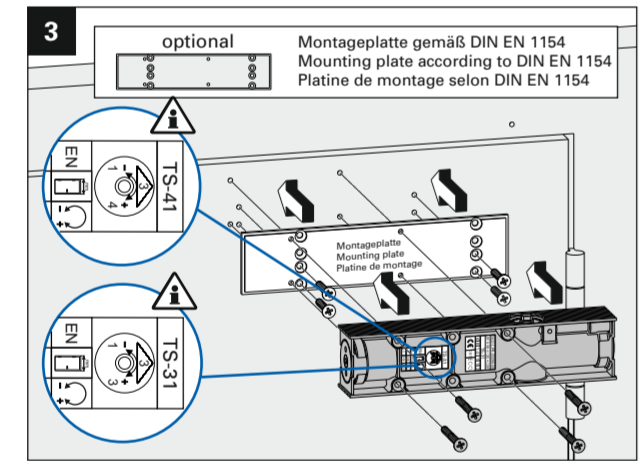
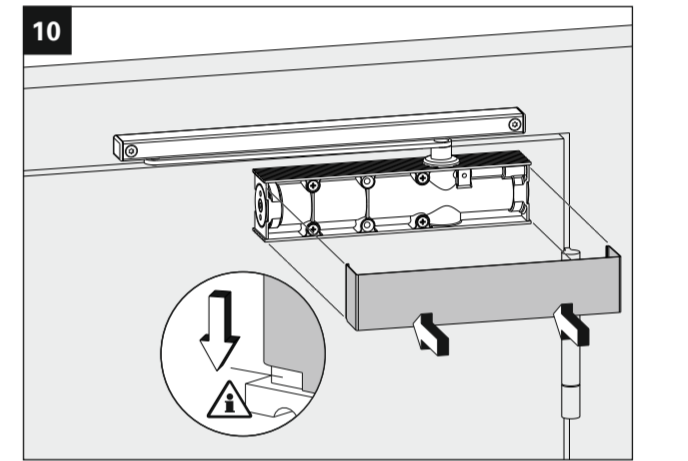
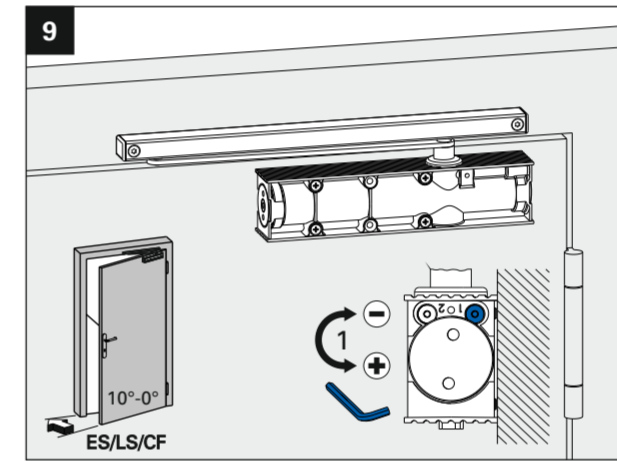
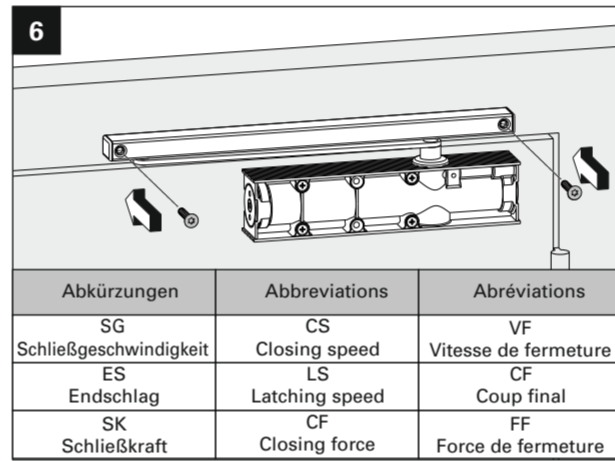
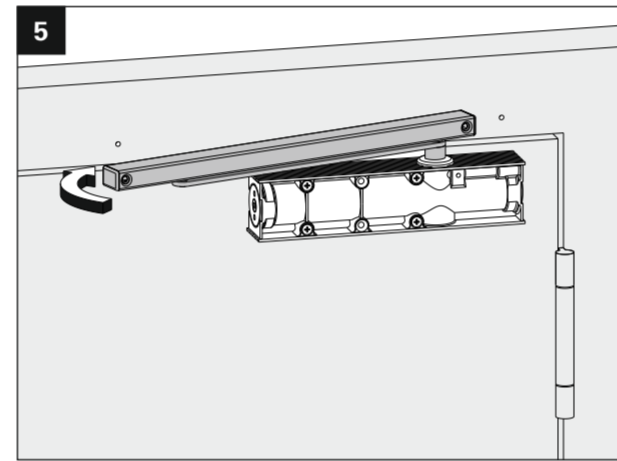
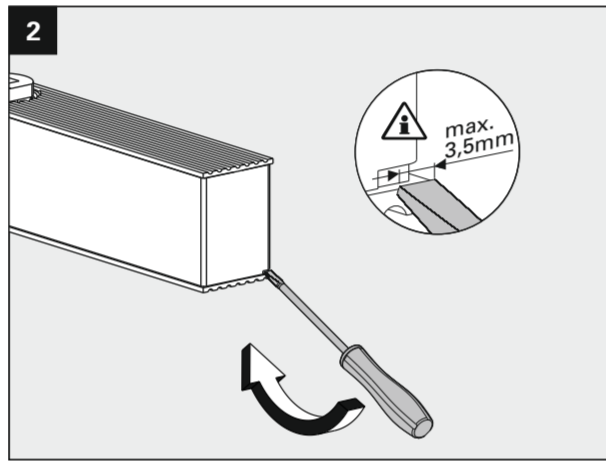
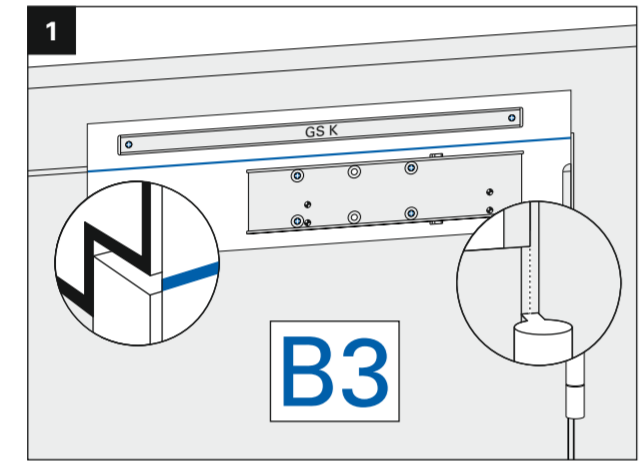

Leistungserklärung nach Verordnung (EU) Nr. 305/2011 finden Sie unter <http://www.eco-schulte.de/leistungserklarungen>
 Declaration of performance according to Regulation (EU) No. 305/2011 see <http://www.eco-schulte.de/declarationofperformance>
 Déclaration des performances conformément au règlement (UE) N° 305/2011 voir <http://www.eco-schulte.de/declarationdesperformances>

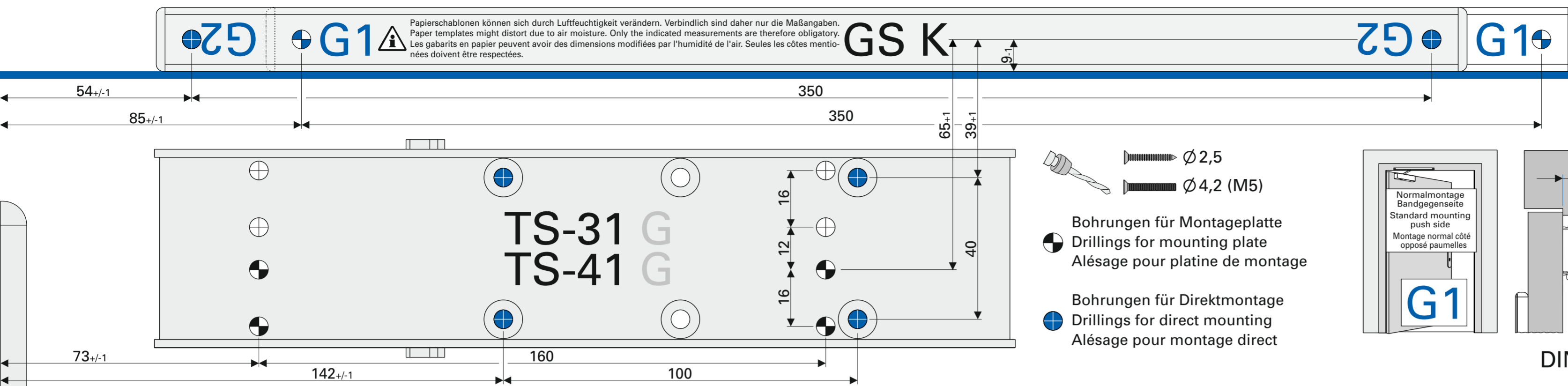

Lochgruppe für Montage Bandgegenseite
 Drillings for mounting pull side
 Alésage de montage côté opposé aux paumelles

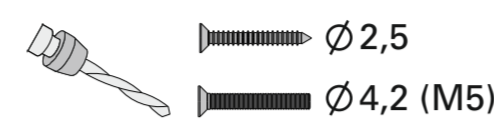

Bohrungen für Montageplatte
 Drillings for mounting plate
 Alésage pour platine de montage

Bohrungen für Direktmontage
 Drillings for direct mounting
 Alésage pour montage direct

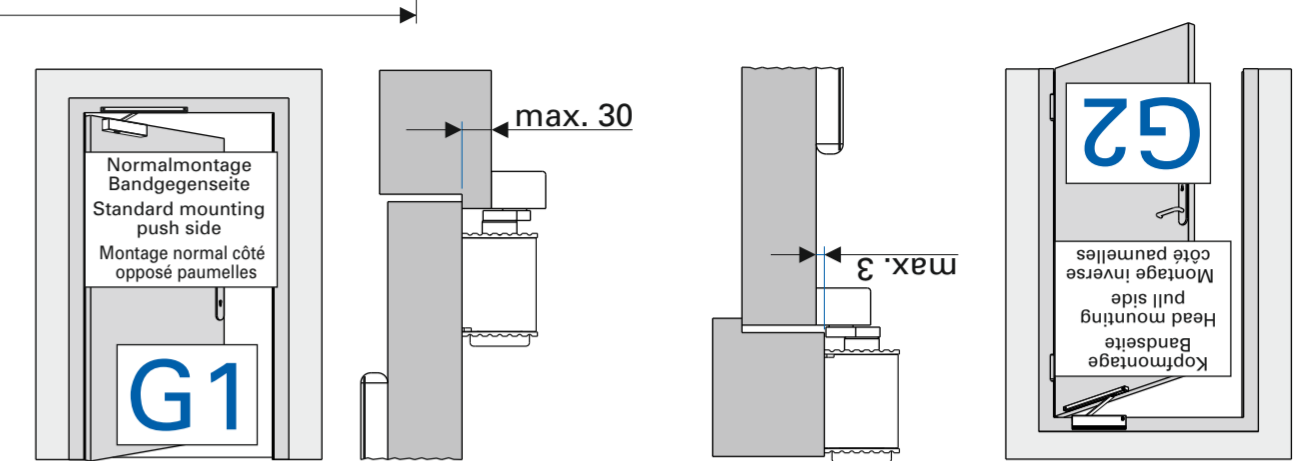

DIN rechts / right / droite

TS-31 K EN 1-3
 TS-41 K EN 1-4

CE	ECO Schulte GmbH & Co. KG Iserlohner Landstraße 89 D-58706 Menden	17
	0432-CPR-00099-09 EN 1154:1996+A1:2002 / AC:2006	4 8 1-3 1 1 3 4 8 1-4 1 1 3

TS-31 EN 1-3	Türschließergröße Door closer size Force de ferme porte	Max. Türbreite Max. door width Largeur de porte max.	Umdrehungen Rotations Rotations
■ 1	750 mm	-11	
■ 2	850 mm	-6	
■ 3	950 mm	0	

TS-41 EN 1-4	Türschließergröße Door closer size Force de ferme porte	Max. Türbreite Max. door width Largeur de porte max.	Umdrehungen Rotations Rotations
■ 1	750 mm	-7	
■ 2	850 mm	-4	
■ 3	950 mm	0	
■ 4	1100 mm	+5	

Für die Montage dürfen ausschließlich Originalteile des Herstellers verwendet werden. Die Montagearbeiten müssen gemäß Anleitung von einer qualifizierten Person durchgeführt werden. Bei Nichtbeachtung entfällt jeglicher Garantieanspruch. Diese Anleitung ist vom Monteur nach der Montage an den Betreiber weiterzugeben!
 Only original parts have to be used. The assembly has to be made by a qualified person according to the mounting instruction. In case of non-respect the guarantee is invalid. This instruction is to be handed over to the operator by the fitter after assembly!
 Impérativement utiliser la notice de montage fournie par le fabricant. La mise en œuvre et le montage doivent être exécutés par du personnel qualifié. Le non respect de ces règles annule catégoriquement tout droit de garantie. Cette instruction est à remettre par le poseur à l'exploitant après montage.

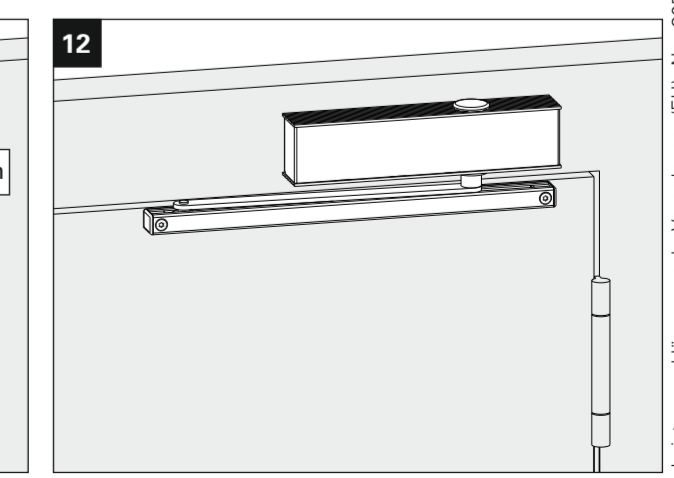
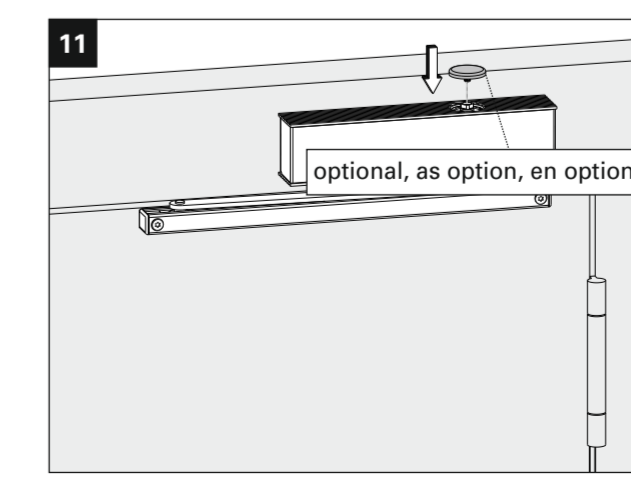
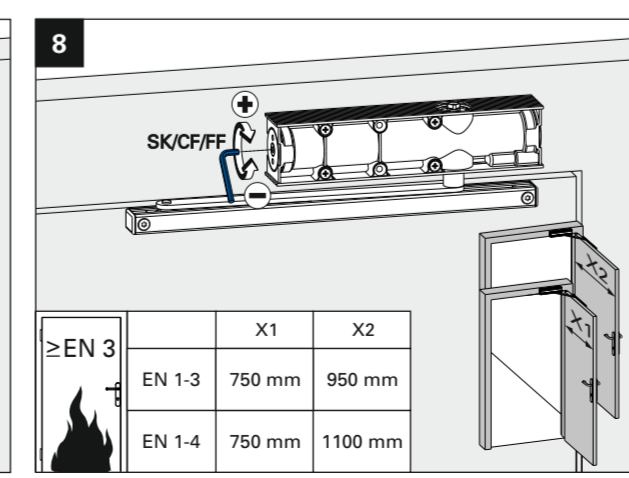
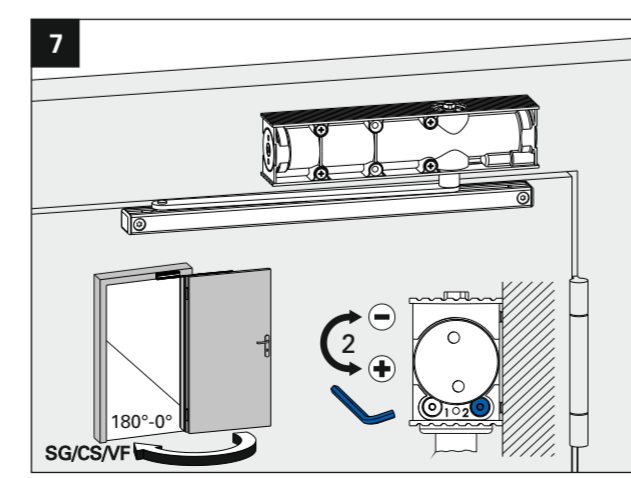
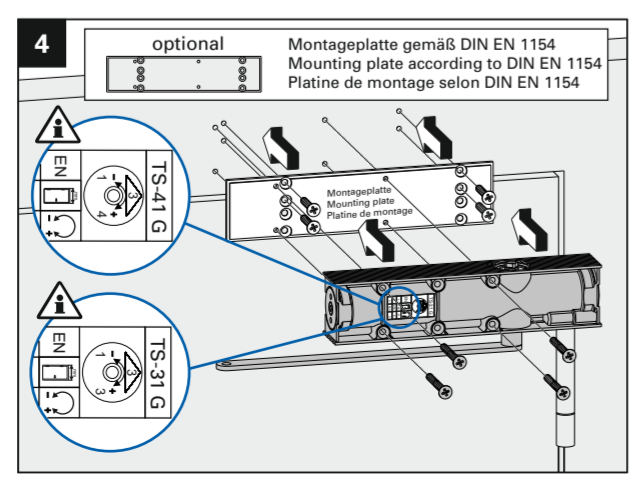
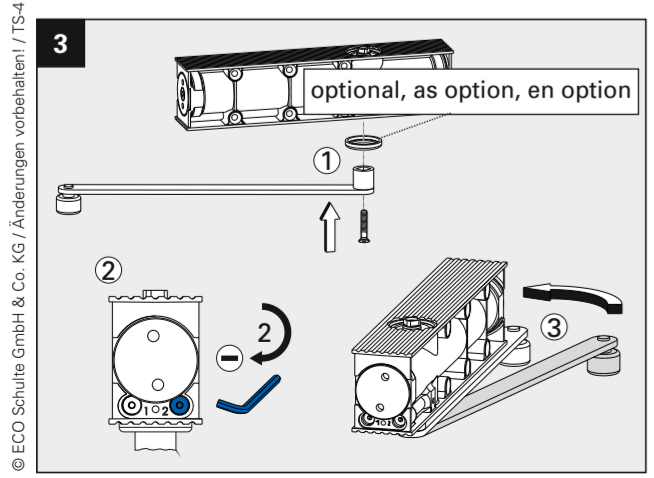
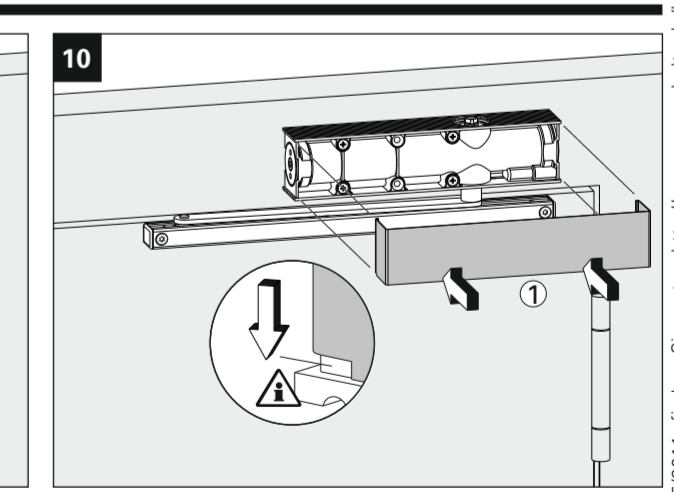
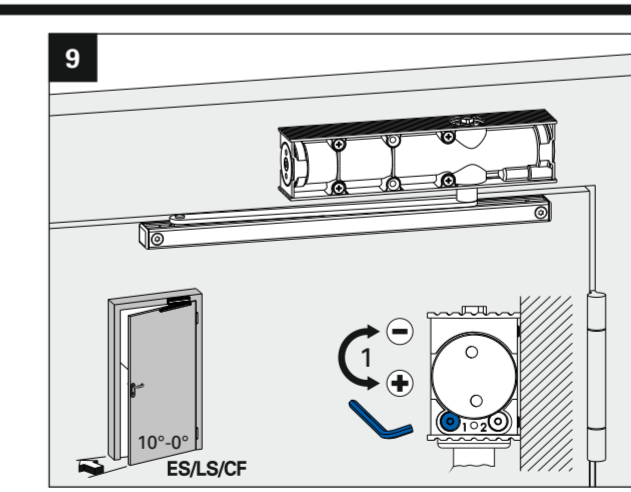
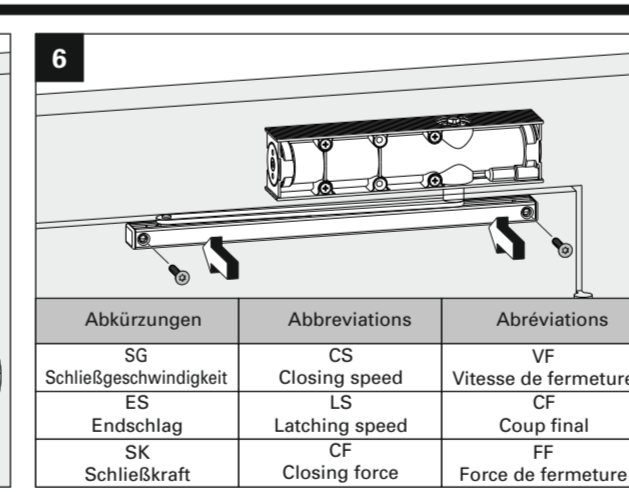
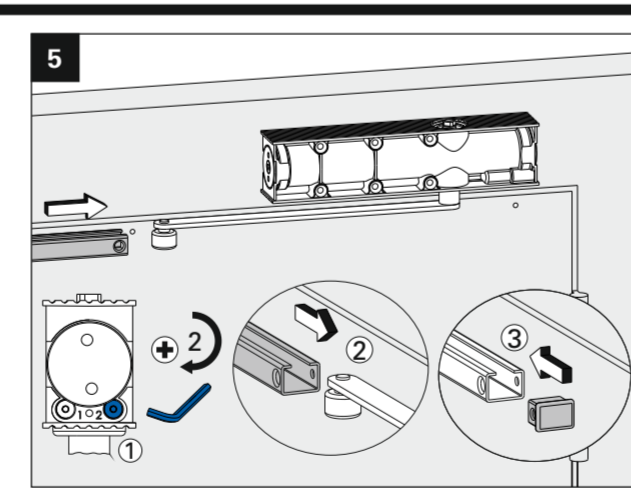
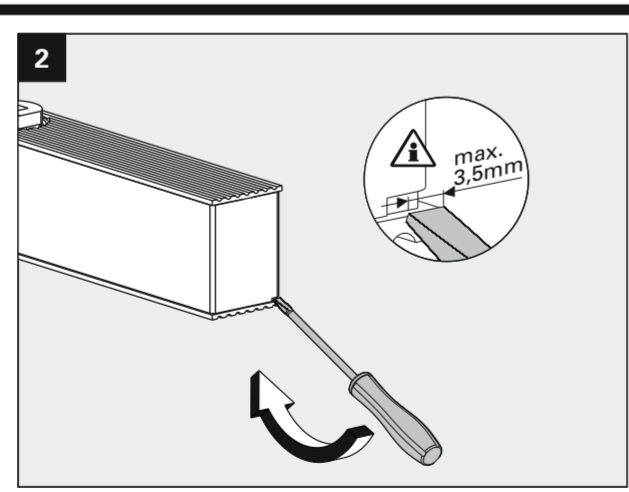
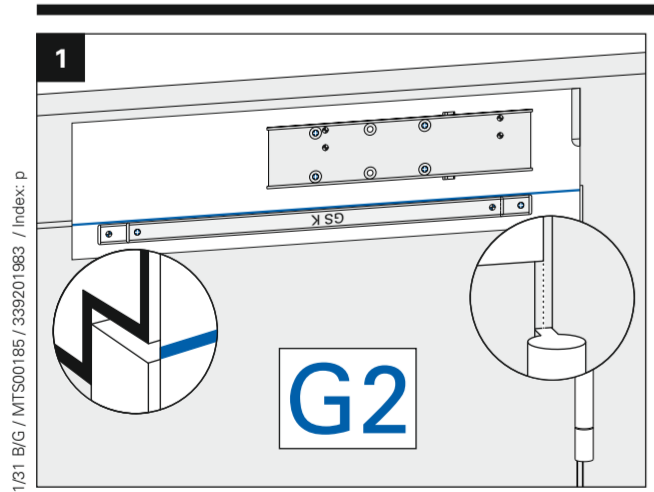
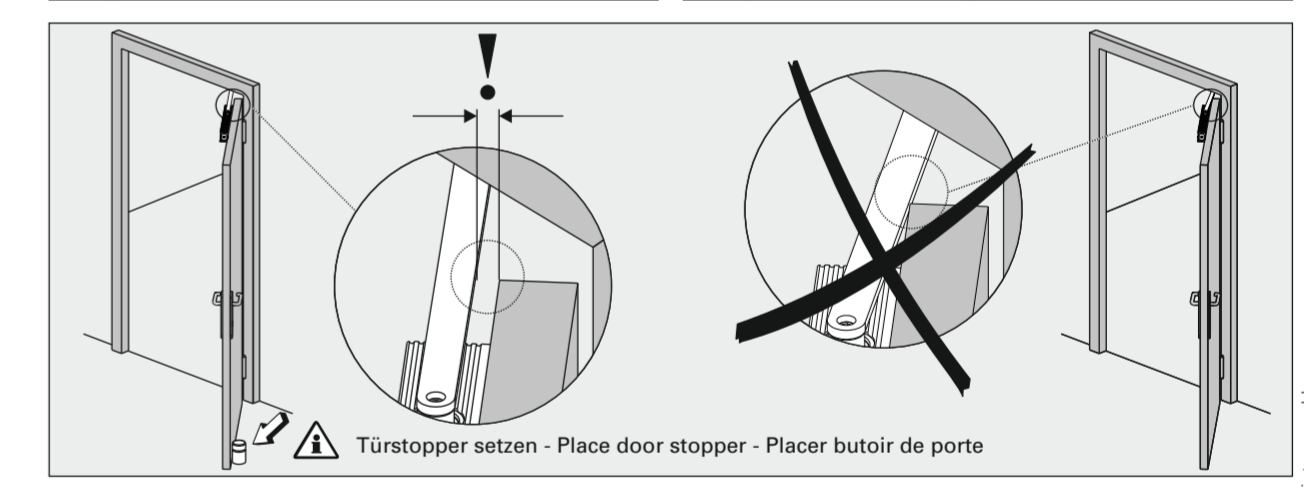
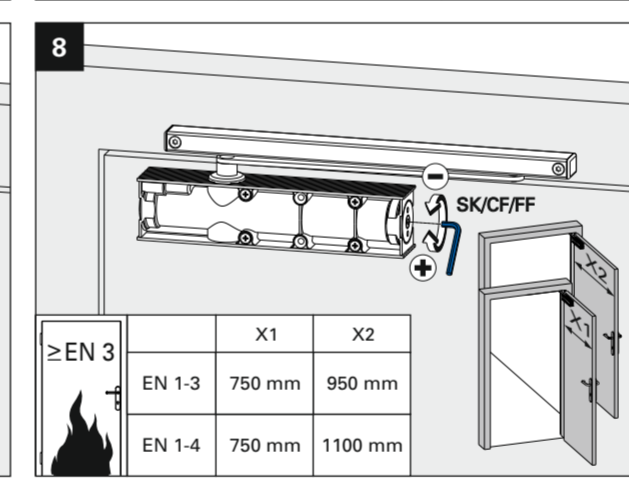
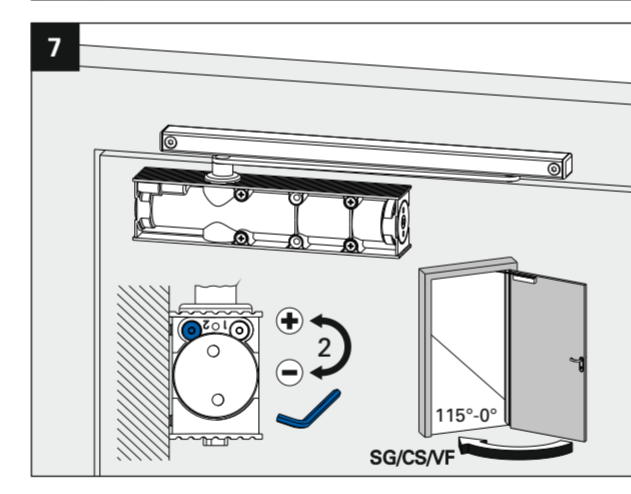
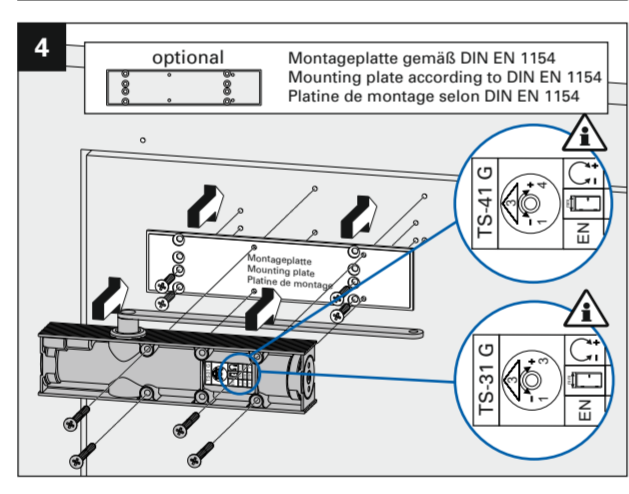
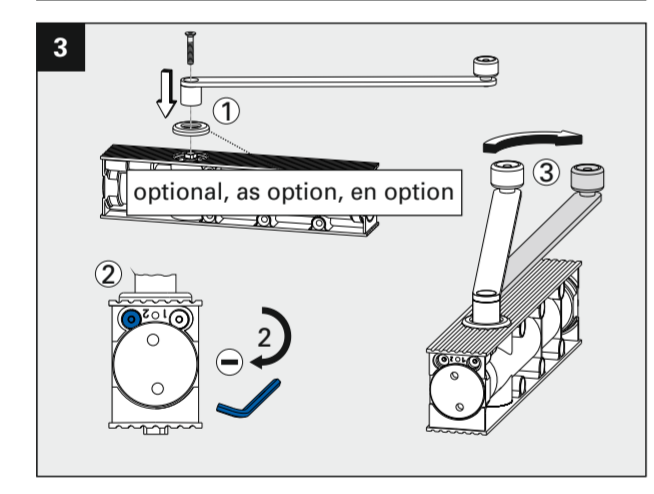
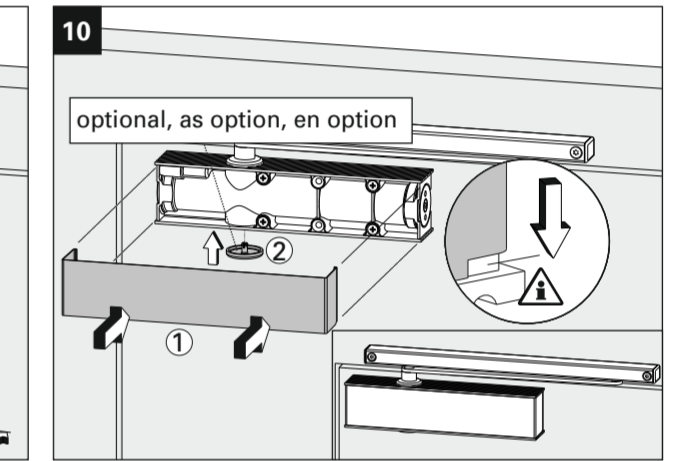
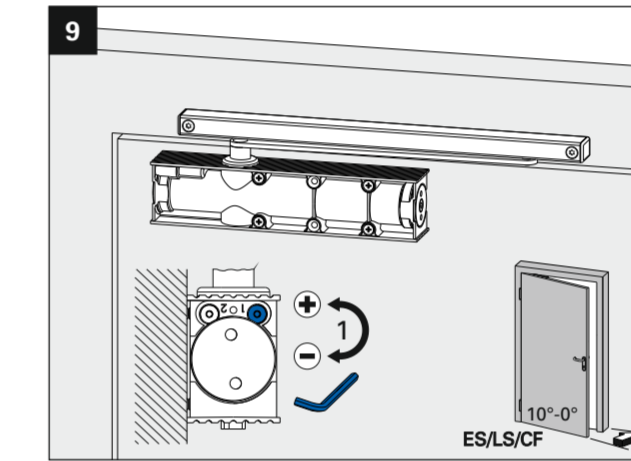
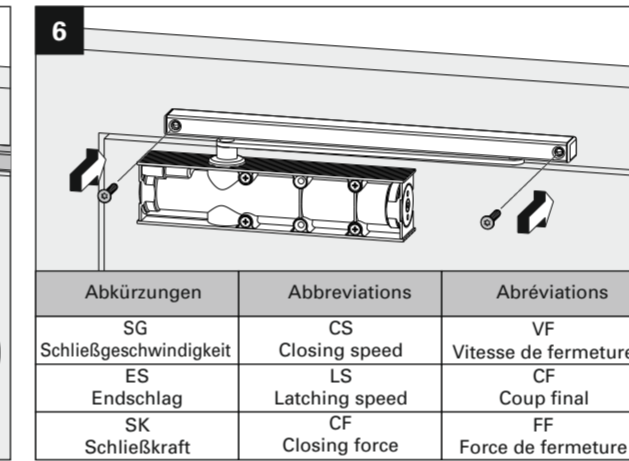
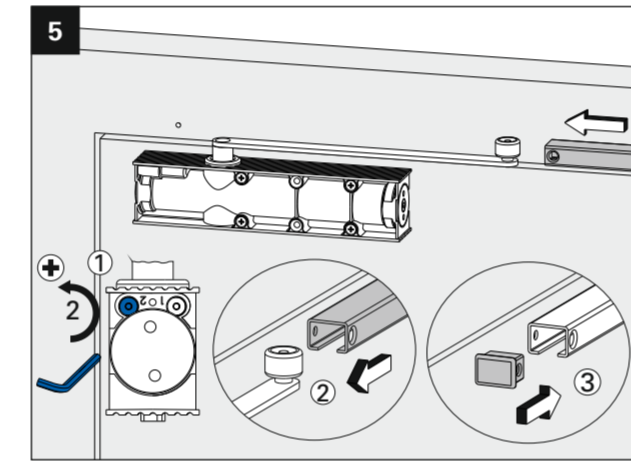
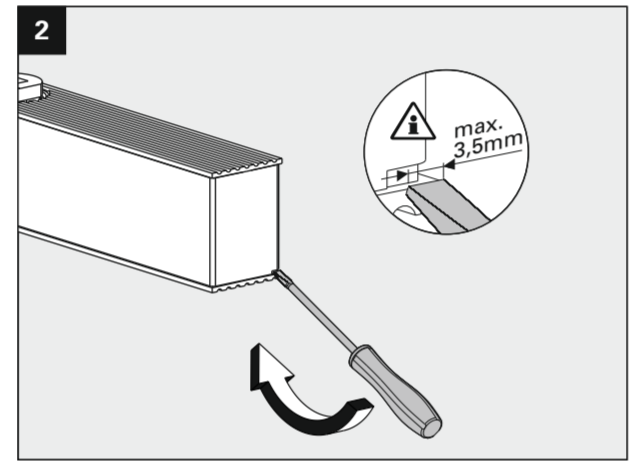
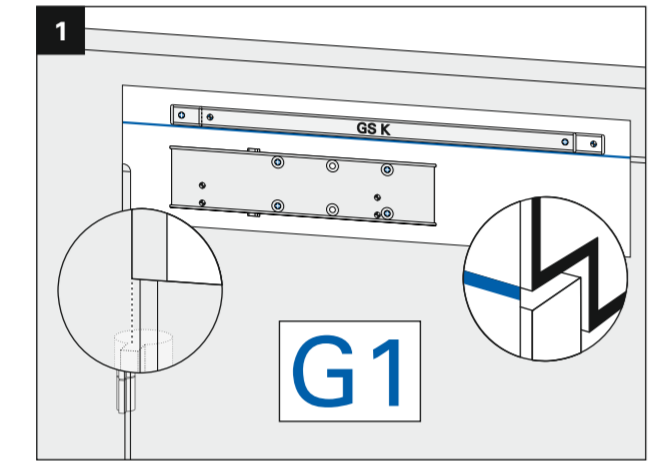

Leistungserklärung nach Verordnung (EU) Nr. 305/2011 finden Sie unter <http://www.eco-schulte.de/leistungserklarungen>
 Declaration of performance according to Regulation (EU) No. 305/2011 see <http://www.eco-schulte.de/declarationofperformance>
 Déclaration des performances conformément au règlement (UE) N° 305/2011 voir <http://www.eco-schulte.de/declarationdesperformances>

Lochgruppe für Montage Bandgegenseite
Drillings for mounting pull side
Alésage de montage côté opposé aux paumelles

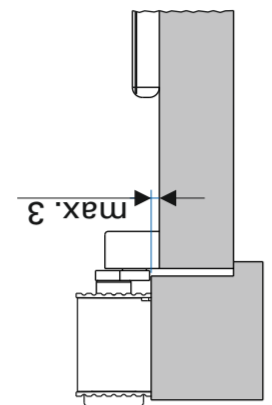
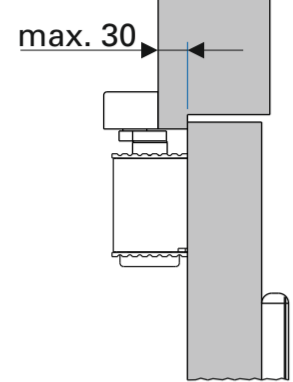
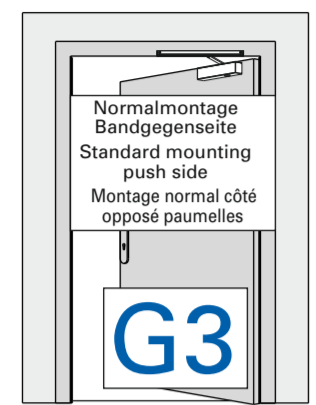

DIN links / left / gauche

- Bohrungen für Montageplatte
Drillings for mounting plate
Alésage pour platine de montage
- Bohrungen für Direktmontage
Drillings for direct mounting
Alésage pour montage direct

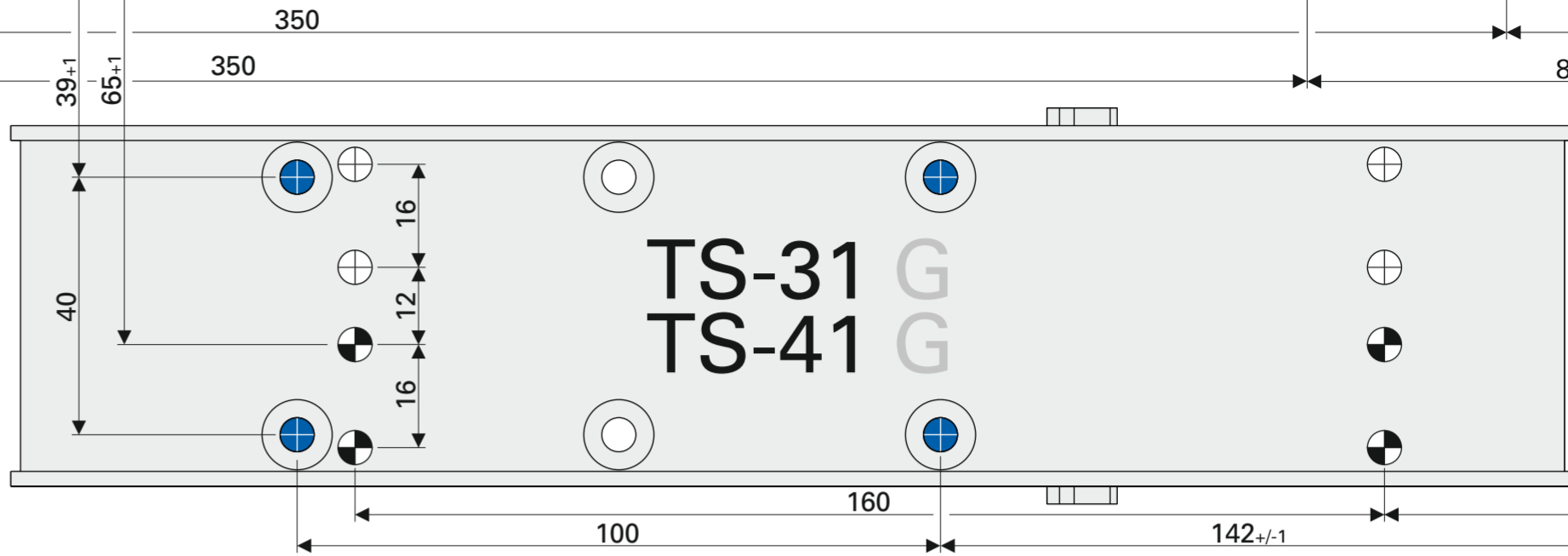

Papiersablonen können sich durch Luftfeuchtigkeit verändern. Verbindlich sind daher nur die Maßangaben.
Paper templates might distort due to air moisture. Only the indicated measurements are therefore obligatory.
Les gabarits en papier peuvent avoir des dimensions modifiées par l'humidité de l'air. Seules les côtes mentionnées doivent être respectées.

TS-31 K EN 1-3
TS-41 K EN 1-4



CE	ECO Schulte GmbH & Co. KG Iserlohner Landstraße 89 D-58706 Menden	17
0432-CPR-00099-09	EN 1154:1996+A1:2002 / AC:2006	4 8 1-3 1 1 3 4 8 1-4 1 1 3

TS-31 EN 1-3	Türschließergröße Door closer size Force de ferme porte	Max. Türbreite Max. door width Largeur de porte max.	Umdrehungen Rotations Rotations
■1	750 mm	-11	
■2	850 mm	-6	
■3	950 mm	0	

TS-41 EN 1-4	Türschließergröße Door closer size Force de ferme porte	Max. Türbreite Max. door width Largeur de porte max.	Umdrehungen Rotations Rotations
■1	750 mm	-7	
■2	850 mm	-4	
■3	950 mm	0	
■4	1100 mm	+5	

Für die Montage dürfen ausschließlich Originalteile des Herstellers verwendet werden. Die Montagearbeiten müssen gemäß Anleitung von einer qualifizierten Person durchgeführt werden. Bei Nichtbeachtung entfällt jeglicher Garantieanspruch. Diese Anleitung ist vom Monteur nach der Montage an den Betreiber weiterzugeben!
Only original parts have to be used. The assembly has to be made by a qualified person according to the mounting instruction. In case of non-respect the guarantee is invalid. This instruction is to be handed over to the operator by the fitter after assembly!
Impérativement utiliser la notice de montage fournie par le fabricant. La mise en œuvre et le montage doivent être exécutés par du personnel qualifié. Le non respect de ces règles annule catégoriquement tout droit de garantie. Cette instruction est à remettre par le poseur à l'exploitant après montage.

